



Operating Manual for Unbalance Motors

in special version for areas with explosive gas atmospheres or in the presence of combustible dust

(Translation of the original operating manual)

Series eUV...-A_

Intended Use

AViTEQ unbalance motors of the series eUV...-A_ that are described in this operating manual are designed as single or double drives for areas with explosive gas atmospheres (zone 1 and 2) or for areas with the presence of combustible dust (zone 21 and 22) with the approval:



LCIE 07 ATEX 6031 X

II 2 G Ex e II T3 and/or T4

II 2 D tD A21 IP66 T ...°C ¹

as drives for vibration (conveyor) devices for discharging, conveying, feeding, compacting, loosening, dosing, and/or screening of bulk materials.

As a three-phase cage motor, the unbalance motor is suited for use with 50 Hz or 60 Hz three-phase mains supplies.

Please also observe the additional remarks about the intended use that are specified in chapter 1.3!

When installing the unbalance motor to a working unit (trough, tube, screen etc.) it is to be made certain that no ignition sources result from colliding components. The vibration (conveyor) device (unit of unbalance motor and working unit) must be able to oscillate freely without effecting neighboring components.

AViTEQ Vibrationstechnik GmbH does not take responsibility for injuries or damages which arise as a result of the use or the application of this product, which deviates from the data in the operating manual.

According to Article 2 Point g) of the Machines Directive 2006/42/EC, the drives are partly completed machinery. Installation instructions according to Appendix VI must be produced for and supplied with these partly completed machinery. Due to the requirements arising from other also applicable EC Directives, a complete operating manual has been produced. This is an integral part of the product. A separate installation manual therefore does not exist. Instead, the description of the installation is part of the operating manual and must be observed accordingly.

¹ The maximum surface temperature is listed in the table 3.1 on page 24.

For your Safety

You will find three different types of symbols in this operating manual which are intended to point out important information:



DANGER!

The danger warning describes procedures or conditions which could lead to dangerous and even life-threatening consequences for the person installing or using the equipment.



ATTENTION!

You will find this information with procedures in which a danger of damage to equipment exists. This damage could also result in injury to personnel (e.g., from a fire or an explosion!).



NOTE

Notes provide information regarding individual tasks. Notes explain circumstances, clarify terminology or provide tips for simplifying processes or procedures.

Even though the AViTEQ unbalance motors were developed with all safety measures for your protection, handling errors may occur. In the interest of your safety and that of your colleagues, please observe the following information:



DANGER!

When the unit is connected to the mains, a perilous voltage is present inside of the terminal box of the unbalance motor. Touching electrically live components can be lethal! Before switching on mains power, ensure that no live parts can be touched! Close the cover of the terminal box and check that all cable glands and all insulations are undamaged!



DANGER!

Never operate the unbalance motor without its protective hoods! Rotating centrifugal weights that are not covered can lead to perilous injuries in the case of touching them! Furthermore, with the types eUVE 7,7Y-A1; eUVE 7X-A1 and eUVE 3W-A1 the protective hoods are part of the bearing shield construction. Check that the protective hoods are mounted properly before you switch on the drive!



DANGER!

Never open the cover of the terminal box, as long as voltage is present at the terminals inside the terminal box, because this can be an ignition sources and as a result lead to an ignition of a potentially explosive atmosphere consisting of a gas-, a vapour-, a mist- or a dust-air-mixture!



DANGER!

*Inadequate installation may cause the unbalance motor to fall down possibly causing injuries. Ensure that the unbalance motor is bolted on tight to the working unit and take appropriate steps to ensure that the unbalance motor cannot fall down! Remaining under the unbalance motor or the vibration (conveyor) device is **not** allowed!*



DANGER!

Parts that collide with other parts can lead to ignition sources. Before first commissioning, make sure that the vibration (conveyor) device can oscillate without colliding with other parts and that all screws are tightened correctly! Remove all loose parts from the vibration (conveyor) device before starting the unbalance motor(s).



DANGER!

After switching off, an unbraked unbalance motor may excite the natural frequency of its support before coming to a halt. Make sure that the vibration (conveyor) device cannot jump out of its support! Always use a braking unit for unbalance motors of sizes eUVG... and larger.



DANGER!

Danger of injuries! During operation the motor housing heats up. Expect surface temperatures up to + 135°C!



ATTENTION!

Every unbalance motor must be operated with a separate motor-protective circuit breaker! It is **not** allowed to add up the currents of several unbalance motors and then operate them with a common motor-protective circuit breaker! The motor-protective circuit breaker has to be set to the value of the rated current (nominal current) of the unbalance motor, as it is shown on the type label of the unbalance motor!

Particularly consider the following data on the type label: I_A/I_N - relationship between the starter current I_A and the rated current I_N and the time t_E , the maximum period for the overload protection to react in the case of overload.

*Operating with two drives, both drives have to be connected in a way that if one drive is switched off the second drive has to be switched off too. A single drive operation is **not** allowed in the case of double drives and may lead to a destruction of the unbalance motors and/or the vibration (conveyor) device! Always observe this!*



ATTENTION!

The unbalance motors are normally delivered without a connexion cable. Select, depending upon your case of application, a connexion cable with a suitable wire and cable cross section, permissible in accordance with the standards that guarantees the degree of protection (IP66) at the cable gland.

If the unbalance motor is operated in areas with explosive gas atmospheres (zone 1 or 2), the temperature of the connexion cable near the cable gland must **not** exceed +105°C relating to the temperature class T4 and +180°C relating to the temperature class T3.

If the unbalance motor is operated in areas with the presence of combustible dust (zone 21 or 22), the temperature of the connexion cable near the cable gland must **not** exceed +120°C.

Choose a connexion cable that is suitable for the maximum temperature. In case of doubt, please contact us.



ATTENTION!

If the unbalance motor is operated in areas with the presence of combustible dust (zone 21 or 22), it is mandatory to connect and use the present PTC thermistor in order to restrict the maximum temperature of the unbalance motor to +120°C or +135°C, depending on the type of the unbalance motor!



ATTENTION!

Unsuitable controllers or operation with the incorrect mains voltage could result in damage to the unbalance motor and is not allowed. Ensure that the connected loads are correct and compare the type labels of the unbalance motor and the braking unit!

It is totally prohibited that the current consumption of the unbalance motor exceeds the value of the nominal current specified on the type label!



ATTENTION!

The permissible mains frequency is stated on the motor's type label. When operating with a different frequency – e.g., when using a frequency converter – ensure that the permissible mains frequency is not exceeded without consulting AViTEQ. Disregarding this may lead to premature failure of the unbalance motor.



ATTENTION!

If the unbalance motor is operated in areas with the presence of combustible dust (zone 21 or 22), the sealing (o-ring) of the cover of the terminal box and the sealings of the protective hoods must be replaced every 2 years. If damages are visible the sealings must be replaced immediately!



ATTENTION!

Prior to welding work on or near the unbalance motor, all supply lines to the unbalance motor (especially the protective earth) must be disconnected from the mains supply. Otherwise the unbalance motor may be damaged!



NOTE

AViTEQ normally delivers the unbalance motors with a mounted cable gland. If the cable gland should be missing or damaged, please choose a suitable cable gland that fulfills the requirements for areas with explosive gas atmospheres (zone 1 and 2) and for areas with the presence of combustible dust (zone 21 and 22) and that has an approval for the equipment group II, category 2G and 2D and at least IP66 (Designation: II 2GD IP66).



NOTE

Operating the unbalance motors with a frequency converter with pulse-width modulation (PWM) is allowed in areas with the presence of combustible dust (zone 21 or 22), if the following general conditions are observed:

- a) The allowed frequency range for the output frequency of the frequency converter is 20 up to 50 Hz with a 50 Hz-mains frequency and 20 up to 60 Hz with a 60 Hz-mains frequency. Further the unbalance motor must be operated with a constant torque (linear voltage-frequency-curve).*
- b) The unbalance motor is **only** allowed to be operated in the zone 21 or 22.*
- c) The unbalance motor must have a PTC thermistor that must be controlled by a PTC thermistor triggering unit that has an ATEX-approval. An exceeding of the allowed surface temperature **must** lead to a switching off of the unbalance motor.*

If the above defined terms are met, a motor-protective circuit breaker with a bi-metal (circuit breaker with an adjustable overcurrent release) is not needed. In fact, a motor-protective circuit breaker with a bi-metal that is located between an unbalance motor and a frequency converter is often activated by mistake by the harmonics that are generated by the frequency converter and therefore this protection device is not useful!

*Operating the unbalance motors with a frequency converter in areas with explosive gas atmospheres (zone 1 or 2) is **not** allowed.*



NOTE

Depending on the construction of the working unit and the acoustic properties of the material transported, the sound pressure level of the operational unbalance motor may exceed 70 dB(A). It is the operator's responsibility to ensure adherence to the sound pressure level permitted by means of suitable noise protection measures!



NOTE

If a thermal overcurrent trip is used, this must be set to the rated current according to the information on the rating plate. The maximum permitted switching frequency for operation with a thermal overcurrent trip is 15 switching operations per hour.



NOTE

In the case of applications in the food industry a special lacquering may be required that is permitted for the food industry. Please observe this to avoid health risks of others.



NOTE

*Unbalance motors in special version for areas with explosive gas atmospheres (zone 1 or 2) or for areas with the presence of combustible dust (zone 21 or 22) are, according to the associated type examination certification, designed and permitted for areas with potentially explosive atmospheres consisting of a gas-, a vapour-, a mist- **or** a dust-air-mixture. A so-called „hybrid operation“, an operation with coexisting potentially explosive atmospheres consisting of a gas-, a vapour-, a mist- **and** a dust-air-mixture is **not** allowed.*

COPYRIGHT

The AViTEQ unbalance motors of the series eUV...-A_ and this operating manual are protected by copyright. Any reengineering of the units will result in criminal prosecution. All rights of this operating manual are reserved, including reproduction via photo mechanical, print, data or any other possible medium, as well as in translation.

Reproduction of this operating manual, complete or in part, requires the written consent of AViTEQ Vibrationstechnik GmbH.

VIBTRONIC® is a registered and protected trademark of AViTEQ Vibrationstechnik GmbH.

This operating manual supports the intended use and appropriate deployment of AViTEQ unbalance motors. For this purpose, the operating manual describes details that are significant for the product's operation.

AViTEQ Vibrationstechnik GmbH is liable for textual errors in the operating manual only where intent and gross negligence are demonstrated. In such cases, liability is limited to the effects the textual errors have on the product specified in the contract and other associated products produced by AViTEQ Vibrationstechnik GmbH as well as required products produced by AViTEQ Vibrationstechnik GmbH which are used in technical combination. This aforementioned liability is limited to cases in which the value or functionality of the agreed upon characteristic of the product specified in the contract is vitiated or considerably diminished. This does not apply if liability for loss of life or limb or loss of health is mandatory.

The textual errors, the damages as well as the justification and resulting causality underlying the liability claim are to be proven by the purchaser. In particular, AViTEQ Vibrationstechnik GmbH is not liable for damages or consequential damages resulting from the incorrect use of the operating manual. This does not apply to faulty content of the operating manual. This does not apply if liability for loss of life or limb or loss of health is mandatory. We are always grateful for suggestions and criticism!

Unless otherwise stated, the relevant state of engineering is that at the time of the combined delivery of the product and the operating manual from AViTEQ Vibrationstechnik GmbH. The product is subject to technical changes without prior notice. Previous operating manuals no longer apply.

The *General Conditions of Delivery Domestic and Abroad* of AViTEQ Vibrationstechnik GmbH apply in their current version.

Do you have questions? Or problems with installation and commissioning?
Give us a call! We'll be glad to help you!

AViTEQ Vibrationstechnik GmbH
Im Gotthelf 16
65795 Hattersheim-Eddersheim
Germany

Phone +49 / 6145 / 503 - 0
Fax +49 / 6145 / 503 - 200
Fax +49 / 6145 / 503 - 112 (Service-Hotline)
E-Mail service@aviteq.de

Hattersheim-Eddersheim, 30th of March 2010

CONTENT

1	We are Partners	10
1.1	About this Operating Manual	10
1.2	Product Liability and Warranty	11
1.3	Operative Range	13
1.4	Installation and Operating Personnel	13
1.5	Safety Instructions regarding the Operating Location	14
1.6	Built-in Safety Systems	14
1.7	Safety Precautions and Responsibilities of the Operator	15
1.8	EC-Directives	15
2	Transport, Storage	16
2.1	Extent of Delivery	17
2.2	Disposal	17
2.2.1	Packing Materials	17
2.2.2	Returning the Device	18
2.2.3	Materials used in the Units	18
3	Device Specification	19
3.1	Principle of Operation	19
3.2	Construction	21
3.3	Sizes	22
3.3.1	Type Designation	22
3.3.2	Housing Sizes and Mounting Hole Dimensions	22
3.4	Sound Pressure Level	24
3.5	Surface Temperatures	24
4	Installation	25
4.1	Mechanical Installation	25
4.1.1	General Remarks	25
4.1.2	Attachment of the Unbalance Motor	25
4.2	Mains Connexion	28
4.2.1	Safety Instructions regarding the Mains Connexion	28
4.2.2	Overload Protection	29
4.2.3	Connexion Cable	29
4.2.4	Connexion Diagram	30
4.2.5	Terminal Connexions inside the Terminal Box	30
5	Commissioning	33
5.1	Adjusting the Centrifugal Force	33
5.2	First Commissioning	36
5.2.1	Single Drive	36
5.2.2	Double Drive	36
5.2.3	Final Check	37
6	Maintenance	38
6.1	Regular Checks	38
6.2	Replacing the Sealings	38
6.3	Bearing Lubrication	39
6.4	Cleaning	42
6.5	Repairs	43
7	Troubleshooting	44
8	Index	45

1 We are Partners

1.1 About this Operating Manual

For whom?

This operating manual is intended for

- Installation technicians installing and/or commissioning the unbalance motor.
- Technicians installing the controller, the electrical connexion to the a.c. mains network and the connexion to the unbalance motor.

All work on the electrical installation must only be carried out by qualified personnel (electricians or persons trained in electrical engineering according to EN 60204-1).

Additional publications

Supplements to this operating manual

- Terminal diagram sheet inside the motor's terminal box
- Note(s) (adhesive label(s)) on the unbalance motor
- ATEX-Type Examination Certificate
- Data sheet of the unbalance motor



NOTE

This operating manual refers only to the unbalance motors of the type: „eUV..-A_“ in special version for areas with explosive gas atmospheres (zone 1 or 2) or areas with the presence of combustible dust (zone 21 or 22)! For the standard design series: „UV..-A_“ a separate operating manual is existing.

Definitions

- **Unbalance motor:** Electric motor with centrifugal weights for operating a vibration (conveyor) device
- **Working unit:** The conveyor unit (trough, tube or screen etc.) in multiple variations
- **Vibration (conveyor) device:** Unbalance motor with the assembled working unit
- **Braking unit:** A separate deliverable electrical controller for the unbalance motor for connecting it with the mains supply

Revision date

On the bottom on the right hand side page of this operating manual, the version number tells you the date when the page was last updated.

Special symbols in this operating manual

Earlier in this manual, you should have learned how we indicate safety notices. If you have any questions about safe work practices regarding the unbalance motor you should give us a call!

For your convenience and orientation, we use the following special indicators in this operating manual:

- A round bullet indicates a listing of characteristics and conditions.
- ☝ The upward showing thumb tells you to check something, or read a summary.
- ☞ The pointing finger indicates steps that you have to carry out.

1.2 Product Liability and Warranty

The drives correspond to the current State of Engineering and have been tested for each of its guaranteed functions prior to delivery. AViTEQ Vibrationstechnik GmbH carries out product and market research to aid further development and continuous improvement. Should malfunctions or failures occur despite these preventative measures, please contact our service department! We guarantee that appropriate measures for the repair of the defect will be taken immediately.

Conditions of Warranty

We guarantee that the product is free of defects within the scope of the technical product specifications published by AViTEQ Vibrationstechnik GmbH as well as technical specifications provided in this operating manual. No declarations of other product features or claims regarding additional characteristics are provided. AViTEQ Vibrationstechnik GmbH is not liable for the economic efficiency of the product or proper functionality when used for applications other than the purpose defined for the product as specified on the first, left-hand inner page in the front of this operating manual.

Warranty Exclusions

Customers and third parties must not undertake work inside or otherwise interfere with the product, except the works that are described in this operating manual. Otherwise, liability for devices, persons and other consequential damages of any type to the product specified in the contract and other legal assets is precluded, provided AViTEQ Vibrationstechnik GmbH is not co-responsible. Entering into or interfering with the equipment also renders any warranty null and void.

AViTEQ Vibrationstechnik GmbH does not accept liability beyond the warranty entitlements stated in our terms of business on which the contract is based. This applies in particular to claims arising from loss of profit or other damage to purchaser/customer assets. This liability limitation does not apply unless the damage was intentional or caused through gross negligence and unless liability for loss of life or limb or loss of health is mandatory. This also does not apply when the purchaser/customer makes a claim for damages based on an incorrect claim of a characteristic or an agreed-upon characteristic. In the event of culpable violation of principle contractual obligations, AViTEQ Vibrationstechnik GmbH is also liable for criminal intent and gross negligence on the part of non-managing employees and for mild negligence. In the latter case, this is limited to the contract-typical, judicious, predictable damages.

Warranty is excluded in particular when the units are used in environments, for purposes, or connected to power supplies or to control systems that are not suitable for the drives or that do not represent the common state of technology. In particular, no warranty is provided for damages caused by unsuitable or incorrect use, incorrect mounting or commissioning by the purchaser/customer or third parties, natural wear, faulty or careless handling or unsuitable operating materials. The same applies for replacement parts, chemical, electrochemical or electrical influences provided they cannot be attributed to AViTEQ Vibrationstechnik GmbH and its employees. Claims made for damages to objects other than that which is specified in the contract, so-called deficiency losses, are limited. In this case, AViTEQ Vibrationstechnik GmbH is liable, regardless of the legal basis, only in the cases of

The "General Conditions of Delivery Domestic and Abroad" of AViTEQ Vibrationstechnik GmbH apply in their current version.

intent, gross negligence on the part of the owner/of its management or managing employee in the event of culpable loss of life or limb or health, in the event of deficiencies which are fraudulently concealed or the absence of which AViTEQ guaranteed, in the event of deficiencies of the delivered object, provided liability is provided in accordance with the product liability law for injury to persons and damages to materials or other special legal requirements.

Likewise, no warranty is provided for damages to conveyance and automation systems which are the result of a malfunction of the product or a textual error in the operating manual. The warranty excludes damages which are the result of accessories not supplied or certified by AViTEQ Vibrationstechnik GmbH. AViTEQ Vibrationstechnik GmbH is not responsible for the violation of patent rights and other titles of third parties outside of the Federal Republic of Germany.

We would like to point out that we are not liable for damage to the product subject to the contract, or for consequential damage to other property, if the damage is caused by non-observation of safety regulations and/or warning notices.

When entering the contract, the purchaser/customer is obliged to point out explicitly if the product is intended for private use and will be used by the purchaser/customer predominantly for this purpose.

The drives described in this operating manual must not be operated without consultation and corresponding release by AViTEQ Vibrationstechnik GmbH in the United States of America and other countries where US American laws are applicable.

1.3 Operative Range

AViTEQ unbalance motors are designed and used as single or double drives for vibration (conveyor) devices for discharging, conveying, feeding, compacting, loosening, dosing, and/or screening of bulk materials. The unbalance motors are not intended for any other purposes.

As a three-phase cage motor, the unbalance motor is suited for use with 50 Hz or 60 Hz three-phase mains supplies.



NOTE

Operating the unbalance motor with a frequency converter at a three-phase mains supply is allowed in areas with the presence of combustible dust (zone 21 or 22). The allowed frequency range for the output frequency of the frequency converter is 20 up to 50 Hz with a 50 Hz-mains frequency and 20 up to 60 Hz with a 60 Hz-mains frequency. In case of doubt, please contact us!

Never use in the following cases:

- *Do not use* with mains voltages and mains frequencies that, according to the information on the type label, are not adapted for the unbalance motor.
- *Do not use* in environmental temperatures below -20°C and above $+40^{\circ}\text{C}$, or in tropical climate! The unbalance motors are designed for operation in moderate climate environments. Special versions for non-moderate climate environments might be possible on request.
- *Do not use* at elevations above 1,000 m above sea level without first consulting AViTEQ Vibrationstechnik GmbH.
- *Do not use* if co-existing potentially explosive atmospheres are consisting of a gas-, a vapour-, a mist- and a dust-air-mixture (so-called hybrid-mixtures) or for conveying explosives.

1.4 Installation an Operating Personnel

Prior to installation and/or commissioning, you must be familiar with all details and connexion configurations of the unbalance motor.

Persons involved with installation, commissioning, assembly, disassembly, adjustment or maintenance must have read and understood this operating manual in its entirety; in particular the safety notes. If you have any questions, we would be glad to help you!



NOTE

Please observe the following remarks, if the unbalance motor is operated in areas with the presence of combustible dust (zone 21 or 22):

- *The selection of the drives and the installation of the units must be carried out by accordingly trained and qualified personnel in compliance with EN 61241-14.*
- *The inspection and maintenance of the drives must be carried out by accordingly trained and qualified personnel in compliance with EN 61241-17.*
- *Repair and overhaul of the drives, as far as allowed, must be carried out by accordingly trained and qualified personnel in compliance with EN 61241-17. The unbalance motors are only allowed to be repaired by AViTEQ Vibrationstechnik GmbH or by special trained and authorised service personnel. AViTEQ Vibrationstechnik GmbH is not liable for damage to property and/or persons in the case of neglect!*



NOTE

Please observe the following remarks, if the unbalance motor is operated in areas with explosive gas atmospheres (zone 1 or 2):

- The selection of the drives and the installation of the units must be carried out by accordingly trained and qualified personnel in compliance with EN 60079-14.
- The inspection and maintenance of the drives must be carried out by accordingly trained and qualified personnel in compliance with EN 60079-17.
- Repair and overhaul of the drives, as far as allowed, must be carried out by accordingly trained and qualified personnel in compliance with EN 60079-19. The unbalance motors are only allowed to be repaired by AViTEQ Vibrationstechnik GmbH or by special trained and authorised service personnel. AViTEQ Vibrationstechnik GmbH is not liable for damage to property and/or persons in the case of neglect!

All work on the electrical installation must only be carried out by qualified personnel (electricians or persons trained in electrical engineering according to EN 60204-1).

1.5 Safety Instructions regarding the Operating Location

- Supports and buildings must be designed to withstand the static load and dynamic stresses of the unbalance motor(s), the vibration (conveyor) device and the bulk material.
- The unbalance motor with the vibration (conveyor) device has to be located in such a way that an adequate safety distance of 120 mm is present on all sides. Working stroke and safety distance must be kept free. Please also observe EN 349.
- For adjustment, inspection, and maintenance purposes, the unbalance motor must be accessible at all times.

1.6 Built-in Safety Systems

The unbalance motor is equipped with:

- Insulation class F (155°C)
- Triple PTC thermistor (1x), the PTC thermistor is used for monitoring the temperature of the unbalance motor and is located at the end of the three winding lines.
- Protective hoods: The unbalance motor is completely closed. This prevents magnetic fields from extruding outside the unbalance motor. The rotating shaft ends are covered by the protective hoods.
- Fixing of the centrifugal weights: Clamping screws and additional locking rings or other suitable types of form-fitting or friction-locked closures secure the built-in centrifugal weights against detachment and slipping.
- Waterproof sealings: The cable gland has a sealing for the appropriate cable diameter. The cover of the terminal box has an o-ring sealing or a molded sealing. The feed through holes between the terminal box and the inner housing are sealed by potting compound. The protective hoods are sealed with o-ring sealings. The bearings are protected by a narrow shaft-gland gap (...located under the protective hoods, v-ring and/or a labyrinth seal).

The unbalance motor must be connected to the mains supply by at least a four-wire power supply system, which must include a separate earth line (PE). For connecting the PTC thermistor, we recommend a seven-wire cable. If the second hole for cable gland is used, a four- and a three-wire cable may be used.

1.7 Safety Precautions and Responsibilities of the Operator

This operating manual is part of the unbalance motor and must be available to qualified personnel at any time. The following has to be observed:

- Qualified personnel must have appropriate tools and test equipment at their disposal.
- Qualified personnel must be trained in safe work practices and must be familiar with the safety notes.
- The operator must obtain a local operating permit and observe any conditions relating to it.
- The applicable conditions in their respective latest version must be complied with. Particularly observe EN 60204-1 which applies for the electrical equipment of machines and which must be applied mandatorily in its area of applicability.
- The operator may only use the unbalance motor if it is in perfect condition and in a proper state.

Please also observe the following:

- All works on the unbalance motor require that you observe the safety notes as they are shown in this operating manual.
- Avoid any work practice that compromises safety in relation to the unbalance motor. **You must not disable any safety mechanisms!**
- Any changes relating to the unbalance motor that could compromise safety must be reported to the operator immediately.

1.8 EC-Directives

According to the EC Directive 2006/42/EC for Machines, Article 2 Point g), the drive is a **partly completed** machine. It is not permitted to start using this unit until it has been established that the completely functional machine in which the drive is installed complies with the provisions of the Machinery Directive. The drive has been built in accordance with this Directive. An associated declaration of incorporation is included on page 47.

The drive also complies with the provisions of the EC Directive 94/9/EC for equipment and protective systems intended for use in potentially explosive areas. An associated declaration of conformity is included on page 46.

2 Transport, Storage

unbalance motors and possible equipment are delivered by AViTEQ in appropriate packaging to ensure that the unbalance motors reach their destination undamaged.



NOTE

If the packing is visibly damaged in a way that indicates damage to the contents, contact the forwarding agent! In further proceedings, take notice of the General Conditions of Business of the forwarding agent in order not to risk your claim for damages by improperly filled out forms!

- ☞ Storage: Unless special agreements concerning packing and storage have been made, the units, either packed or unpacked, must be stored and transported under „normal“ conditions. This means in enclosed rooms with temperatures between +5°C and +65°C, relative humidity not exceed 60% (...no condensation) and no mechanical shocks or vibrations.
- ☞ Storage without packaging: Treat unpainted surfaces of the cast housing (feet with mounting holes) with rust protection grease, which must be removed again prior to installation.
- ☞ Period of storage: The period of storage should not exceed 3 years, because after a period of 3 years the grease inside the bearings ought to be changed.



DANGER!

Danger of perilous injuries! Do not stand under a suspended load!

*Do not attach any additional loads to the unbalance motor for transporting it with hoisting devices. The ring bolts are designed for the weight of the motor only and may break. **Never** lift the vibration (conveyor) device using the unbalance motor's ring bolts! Further observe the weight of the unbalance motor when choosing the appropriate hoisting device!*

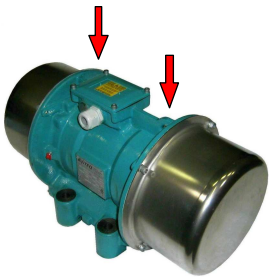

When transporting the unpacked unbalance motor, it is easy to avoid damage by observing the following points:

Transport unbalance motors from size „eUVE...“ upwards only with appropriate hoisting devices, e.g. cranes, forklifts, etc.!

On the upper side, next to the terminal box, the unbalance motor has two ring bolts for transport purposes. These may be used for attaching chains or other hoisting devices. **The centre of gravity is located in the centre of the unbalance motor!**

- ☞ Always grab the unbalance motor from the underside if you wish to carry it!
- ☞ Avoid contact with pointed or sharp (metallic) objects that could damage the protective lacquer coating!
- ☞ Always place the unit onto a secure support base and position, such that the unit cannot tip or fall down!



ATTENTION!

Transporting and storing the units under inappropriate conditions may cause permanent damage. Such damage may not be detectable from the outside. AViTEQ does not cover this case in its warranty and is not liable for any consequential damage.

Make sure that the unbalance motor is not exposed to hard mechanical impacts. The centrifugal weights can exert unacceptably large forces onto the motor's bearings! This may lead to permanent damage!

If you have to ship the unbalance motor back to us, please package and ship it in such a way that it is safe from shocks!

2.1 Extent of Delivery

After unpacking, check the delivery note and accompanying documentation to ensure that all the parts have been supplied and are undamaged. These are...

- Unbalance motor(s)
- Operating manual
- Terminal diagram sheet inside the motor's terminal box
- Rubber foam frames inside the terminal box that are required to dampen vibrations of the connexion cables
- Nuts (normal or self-locking) and plain washers for the cable connexion (Pouch inside the terminal box or attached to the outer housing)

Compare the information on the type label of the unbalance motor with the delivery note and order documentation!

If applicable, verify that the unbalance motor is compatible with the braking unit or the intended frequency converter! If in doubt, please contact us. We'll be glad to help you.



ATTENTION!

Destruction of unbalance motor and braking unit possible if the units don't match! Mains voltage, mains frequency, and oscillation frequency must correspond! The nominal current of the braking unit has to be equal or greater than the maximum current of the unbalance motors. Only interconnect units that match!

2.2 Disposal

2.2.1 Packing Materials

The following materials are used by AViTEQ for delivering the unbalance motors, depending on the type of transport:

- Polyethylene foil (PE) for device protection
- Corrugated cardboard for outer and inner packing
- Wooden cases for outer packing
- Paper shavings as filler material
- Styrofoam (Flo-Pack) as filler and cushioning material

All packing materials should be disposed of in accordance with local regulations of the delivery destination.



Cardboard containers and paper packing tapes can be recycled within the RESY Disposal and Re-utilisation System. Where used, packaging foil, packing tapes, and foam foils are made from polyethylene (PE), the CFC-free cushions are usually made from polystyrene foam (PS). These packing materials consist of pure hydrocarbons and can thus be recycled.

In special cases we use steel packing bands and wooden cases free of chemical treatment.

2.2.2 Returning the Device

AViTEQ Vibrationstechnik GmbH will accept without charge unbalance motors, type: eUV... that have been delivered in 2000 or later when delivered shipping paid to AViTEQ Vibrationstechnik GmbH, 65795 Hattersheim-Eddersheim, Germany.

AViTEQ guarantees for a professional disposal. Therefore the unbalance motors have to be free of product arrears and pollutants. Otherwise AViTEQ is justified to refuse the acceptance of the drive.

2.2.3 Materials used in the Units

In case of disposal by the customer, and when exchanging components, the current local waste and disposal regulations apply and should be observed. We accept no responsibility for improperly disposed parts and components.

For disposal of the lubricant, please observe the appropriate specifications released by the lubricant producer and the valid local environmental regulations. If needed ask the manufacturer about the composition of the lubricant.



NOTE

More detailed information on the materials used is available from us on request. In case of doubt, please do make use of our recycling service!

3 Device Specification

3.1 Principle of Operation

AViTEQ unbalance motors are designed and used as single or double drives for vibration (conveyor) devices for discharging, conveying, feeding, compacting, loosening, dosing, and/or screening of bulk materials.



NOTE

The transport of bulk materials results from the utilisation of the mechanical oscillations that are generated by the unbalance motor(s). The oscillation movement is transmitted from the unbalance motor to the vibration (conveyor) device via the feet of the motor.

It is possible to generate elliptic, circular or linear oscillation movements. The centrifugal forces and so the capacity can be adjusted during standstill by altering the centrifugal weights.

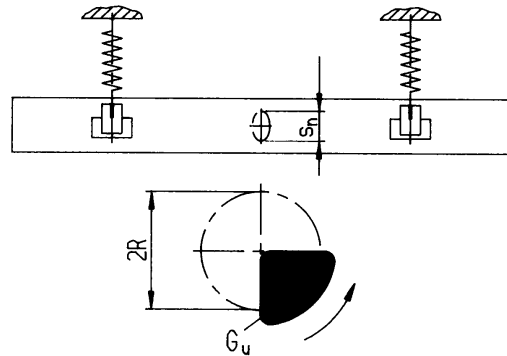

Principle of operation for a single drive: circular or elliptic oscillation movement

If a single drive is located at the centre of gravity, it generates a circular oscillation. Away from the centre of gravity, an elliptic oscillation movement is generated.

A double drive of two unbalance motors rotating in opposite directions generates a linear (straight line) oscillation movement. In this case, the two asynchronous motors mutually synchronise each other due to the forces acting on their centrifugal weights. The appropriate figure is shown on the following page. The oscillation movement depends on the overall centre of gravity of the entire vibration (conveyor) device.

The vibration (conveyor) device may be designed as a trough, tube, screen, bunker, chute, table or similar. If a double drive is installed with both unbalance motors rotating in the same direction, e.g. for circular conveyors or spiral conveyors, a helical oscillation movement is generated.

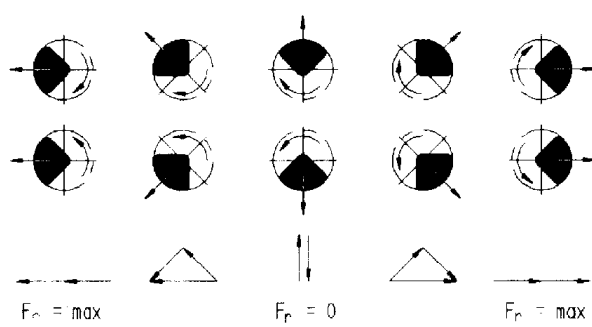
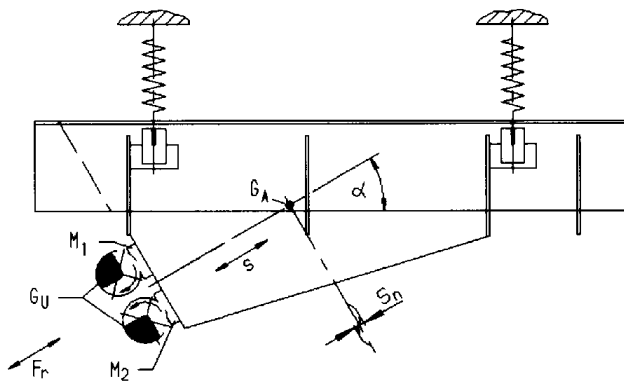

- F_r = Resulting force
- G_A = Weight of the working side (working unit)
- G_U = Weight of the unbalance motors
- M_1 = Unbalance motor 1
- M_2 = Unbalance motor 2
- s = Direction of oscillation movement
- s_n = Working stroke of the working unit
- α = Angle of impact

Principle of operation for a double drive: linear oscillation movement

3.2 Construction

The two ends of the motor shaft of the three-phase cage motor are covered by protective hoods. The terminal box is an integrated part of the motor housing.

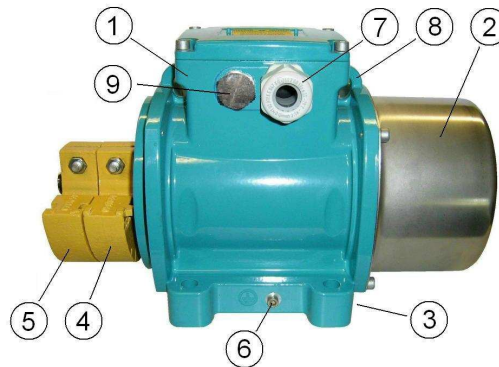

- 1 Terminal box with cover
- 2 Protective hood (...left protective hood is removed)
- 3 Feet with mounting holes
- 4 Centrifugal weight (fixed) or segmented disc(s)
- 5 Centrifugal weight (adjustable) or segmented disc(s)
- 6 Grounding screw
- 7 Cable gland
- 8 Ring bolt (on both sides), depending on the motor size
- 9 Blind plug for a second cable gland (M20x1,5)

Construction of the unbalance motor, using type „eUVD 4X...” as an example

3.3 Sizes

3.3.1 Type Designation

AViTEQ – unbalance motors are available in different sizes and executions. The type designation contains the following information:

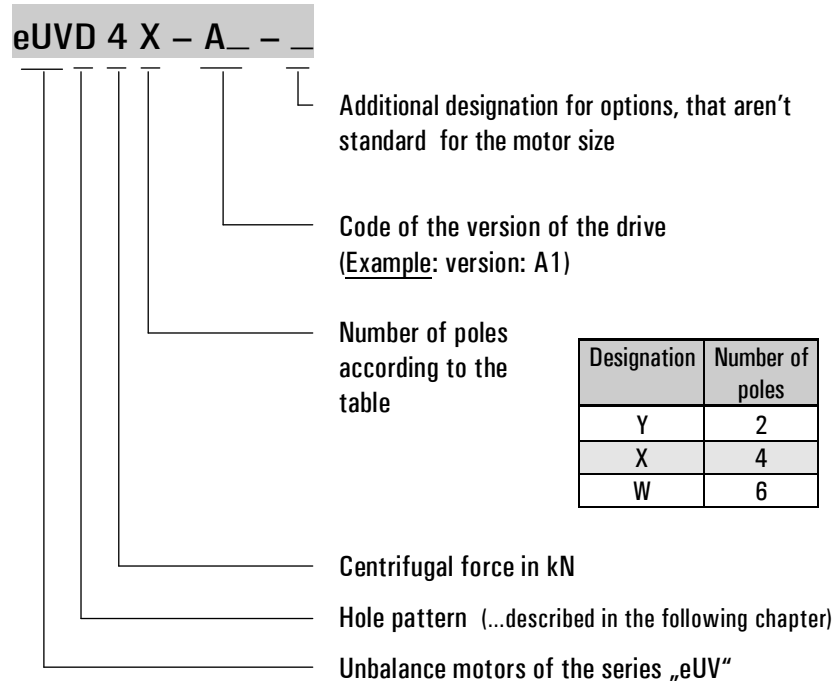

3.3.2 Housing Sizes and Mounting Hole Dimensions

The dimensions are contained in the product specifications for AViTEQ unbalance motors or in the brochure, which are available separately.

On the following page you can find the dimensions of the hole pattern for every unbalance motor. Depending on the size, the unbalance motor is fixed with 4 or 6 screws.

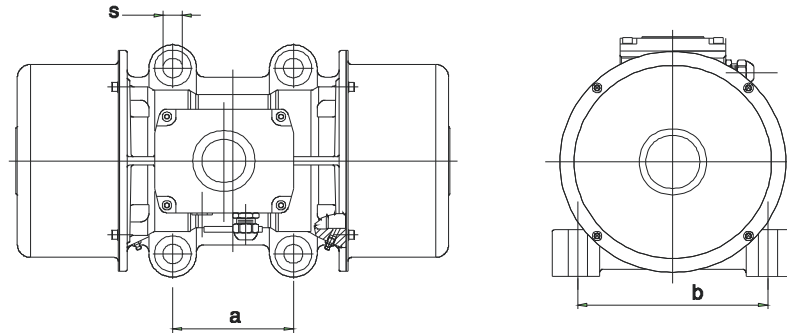

Designation (Hole pattern)	a [mm]	b [mm]	s [mm]	Number of mounting holes (Screw size)
B	64-72	106	9	4 (M8)
C	90	125	13	4 (M12)
D	105	140	13	4 (M12)
E ⁽¹⁾	120	170	13	4 (M12)
E ⁽²⁾			17	4 (M16)
F	125	210	17	4 (M16)
G	165	260	26	4 (M24)
H	280	290	26	4 (M24)

(1) eUVE 7,7Y-A1; eUVE 7X-A1; eUVE 3W-A1; eUVE 11Y-A1 ; eUVE 10X-A1 and eUVE 5W-A1

(2) eUVE 7,7Y-A2; eUVE 7X-A2; eUVE 3W-A2

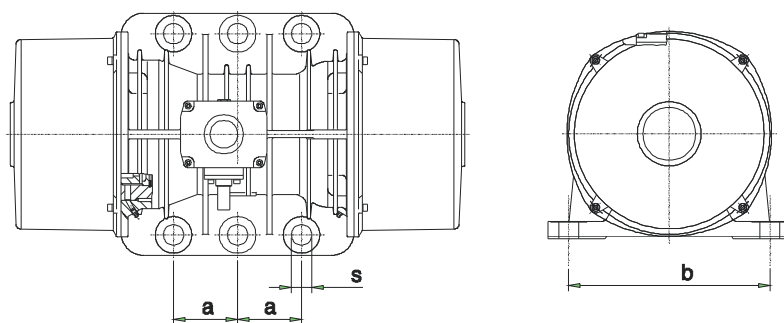

Designation (Hole pattern)	a [mm]	b [mm]	s [mm]	Number of mounting holes (Screw size)
N	125	380	38	6 (M36)

3.4 Sound Pressure Level

The unbalance motor generates a sound pressure level of less than 70 dB(A) without considering the working unit or the transported material. Depending on the construction of the working unit and the acoustic properties of the material transported, the sound pressure level of the operational unbalance motor may exceed 70 dB(A). It is the operator's responsibility to ensure adherence to the sound pressure level permitted by means of suitable noise protection measures.

3.5 Surface Temperatures

The following table contains the maximum surface temperatures of the different unbalance motor types depending on the used PTC thermistor.

Unbalance motor types: 50 (60) Hz oscillation frequency	Unbalance motor types: 25 (30) Hz oscillation frequency	Unbalance motor types: 16 ^{2/3} (20) Hz oscillation frequency	Maximum surface temperature referring to an allowed ambient temperature of +40 °C with a ...	
			120°C PTC thermistor	130°C PTC thermistor
eUVB 1Y-A_ eUVB 1,9Y-A_ eUVC 3Y-A_ eUVD 5Y-A_ eUVE 7,7Y-A_ eUVE 11Y-A_ eUVF 20Y-A_	eUVB 0,3X-A_ eUVB 0,7X-A_ eUVC 1,5X-A_ eUVC 2,1X-A_ eUVD 4X-A_ eUVD 5,4X-A_ eUVE 7X-A_ eUVE 10X-A_ eUVF 18X-A_ eUVF 24X-A_ eUVG 38X-A_ eUVH 49X-A_ eUVN 83X-A_	eUVE 3W-A_ eUVE 5W-A_ eUVF 11W-A_ eUVF 16W-A_ eUVG 21W-A_ eUVH 38W-A_ eUVN 95W-A_	+ 120°C	+ 135°C

Table 3.1 Maximum surface temperatures



NOTE

Always observe the maximum surface temperature and the allowed ambient temperature that are shown on the type label! The allowed ambient temperature according to the type label must not be exceeded! In the case of non-observance unacceptable warming may be the result that can lead to a destruction of the unbalance motor!

4 Installation

4.1 Mechanical Installation

4.1.1 General Remarks

- 👉 Please read the safety notices at the beginning of this operating manual!
- 👉 Specially observe the remarks about the installation site in chapter 1.5!
- 👉 After installing the unbalance motors, no welding may be carried out on the vibration (conveyor) device as this may cause the mounting surfaces to distort. Damage to the motor windings and the bearings are also possible, caused by the welding! If welding has to be carried out, please clarify this point with AViTEQ before carrying out the work.



NOTE

If the working unit including the unbalance motors have been delivered by AViTEQ as a unit, normally the unbalance motors ought to be mounted by AViTEQ. In this case you can skip chapter 4.1.2 and go on with chapter 4.2 (Mains Connexion).



NOTE

From motor size „eUVE...“ upwards we recommend to install a steel safety cable to catch an unbalance motor that detaches itself. This steel cable must be sufficiently thick and of an appropriate length to be able to catch the motor. The motor must not fall more than 15 cm. The steel cable must be attached to one of the ring bolts with an appropriate shackle or a suitable clamping device!

4.1.2 Attachment of the Unbalance Motor



DANGER!

Danger of crushing! Avoid unintended swinging of the unbalance motor on the hoist during the transport. Further prevent the unbalance motor from falling down by securing it appropriately!

The unbalance motors may be installed in any position. However, the mounting surface must be absolutely even!

Proceed as follows:

- 1 Clean the mounting surfaces on the unbalance motor and on the vibration (conveyor) device to remove dirt, oil, and paint. The mounting surfaces must be even, burr-free, and stiff. The surface roughness must not exceed 50 micrometers.
- 2 Position the unbalance motor with an appropriate hoisting device on the vibration (conveyor) device such that its mounting holes line up with those on the vibration (conveyor) device.
- 3 Clean the screw threads to remove oil residue. In the case of threaded holes, wet the screw thread with Loctite 245 (for threads smaller than M 12 use Loctite 275). Observe the notices on the package!



NOTE

*Only use mounting screws/bolts with a bolt quality of at least 8.8!
The mounting surface for the unbalance motor must be absolutely even to prevent the feet of the unbalance motor from cracks and breakings! Please observe this!*

- 4 Screw the unbalance together with the vibration (conveyor) device. Tighten the mounting screws with the torque indicated in table 4.1.

Screw size	Tightening torques (Bolt quality 8.8)
	[Nm]
M 5	5,9
M 8	25
M10	49
M12	85
M16	210
M24	730
M36	2360

Table 4.1 Screw tightening torques



NOTE

According to the recommendation shown in chapter 6.1, please check if there is a reduction of the screw tightening torque caused by subsidence and retighten the screws if required to avoid the unbalance motors from becoming loose!

- 5 In the case of through holes, each nut must be secured by a locknut. If it is not possible to use such a locknut, the nut must be secured using Loctite, just as in the case of threaded holes.

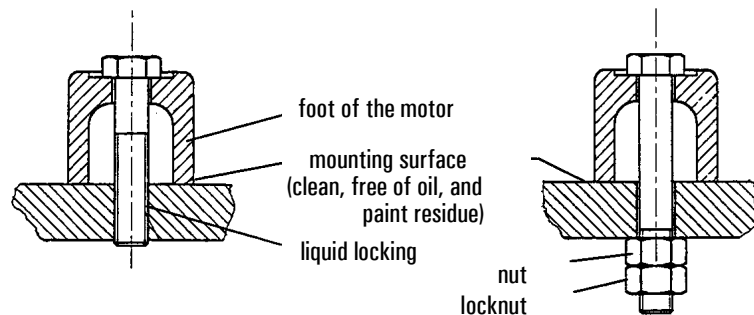

- 6 Alternative: Depending on the vibration (conveyor) device it is possible to use stud bolts and locknuts (...on the unbalance motor's side, as on the photo to the left).



NOTE

Did you know? By far the largest percentage of all damages and disruptions are caused by insufficient attachment of the unbalance motor.

Loctite is a trademark of the company Henkel KGaA.

4.2 Mains Connexion

4.2.1 Safety Instructions regarding the Mains Connexion



DANGER!

Avoid accidents, observe regulations! Regulations and guidelines of your power company apply to the connexion of earth, neutral line, and protective circuitry! The connexion must be carried out only by qualified personnel (electricians or persons trained in electrical engineering according to EN 60204-1).

Switch off the mains supply, check that no voltage is present and protect against unintentional reconnexion!

If the unbalance motor is operated in areas with the presence of combustible dust (zone 21 or 22) or in areas with explosive gas atmospheres (zone 1 or 2) the electrical installation has to be carried out with great care. Earth the housing of the unbalance motor with the support construction. An appropriate grounding screw (position 6 on page 21) is located at the outer housing. Never open the cover of the terminal box, as long as voltage is present at the terminals inside of the terminal box, because this is an ignition source. In the case of neglect there is the danger of an explosion!



ATTENTION!

If the unbalance motor is operated in areas with the presence of combustible dust (zone 21 or 22), it is mandatory to connect and use the present PTC thermistor in order to restrict the maximum temperature of the unbalance motor to +120°C or +135°C, depending on the type of the unbalance motor!



NOTE

Operating the unbalance motors with a frequency converter with pulse-width modulation (PWM) is allowed in areas with the presence of combustible dust (zone 21 or 22), if the following general conditions are observed:

- a) The allowed frequency range for the output frequency of the frequency converter is 20 up to 50 Hz with a 50 Hz-mains frequency and 20 up to 60 Hz with a 60 Hz-mains frequency. Further the unbalance motor must be operated with a constant torque (linear voltage-frequency-curve).*
- b) The unbalance motor is **only** allowed to be operated in the zone 21 or 22.*
- c) The unbalance motor must have a PTC thermistor that must be controlled by a PTC thermistor triggering unit that has an ATEX-approval. An exceeding of the allowed surface temperature **must** lead to a switching off of the unbalance motor.*

If the above defined terms are met, a motor-protective circuit breaker with a bi-metal (circuit breaker with an adjustable overcurrent release) is not needed. In fact, a motor-protective circuit breaker with a bi-metal that is located between an unbalance motor and a frequency converter is often activated by mistake by the harmonics that are generated by the frequency converter and therefore this protection device is not useful!

*Operating the unbalance motors with a frequency converter in areas with explosive gas atmospheres (zone 1 or 2) is **not** allowed.*

4.2.2 Overload Protection

Unbalance motors are usually connected to the three-phase mains via a braking unit or a frequency converter. The overload protection must be carried out in compliance with the National Standards and the European Directive for areas with explosive gas atmospheres (zone 1 or 2) or areas with the presence of combustible dust (zone 21 or 22).



ATTENTION!

Every unbalance motor must be operated with a separate motor-protective circuit breaker! It is not allowed to add up the currents of several unbalance motors and then operate them with a common motor-protective circuit breaker! The motor-protective circuit breaker has to be set to the value of the rated current (nominal current) of the unbalance motor, as it is shown on the type label of the unbalance motor!

*Operating with two drives, both drives have to be connected in a way that if one drive is switched off the second drive has to be switched off too. A single drive operation is **not** allowed in the case of double drives and may lead to a destruction of the unbalance motors and/or the vibration (conveyor) device! Always observe this!*

Further following terms have to be observed, if the unbalance motor is operated with a frequency converter in areas with the presence of combustible dust:

- a) *The unbalance motor is **only** allowed to be operated in the zone 21 or 22.*
- b) *The unbalance motor must have a PTC thermistor that must be controlled by a PTC thermistor triggering unit that has an ATEX-approval. An exceeding of the allowed surface temperature **must** lead to a switching off of the unbalance motor.*

If the above defined terms are met, a motor-protective circuit breaker with a bi-metal (circuit breaker with an adjustable overcurrent release) is not needed. In fact, a motor-protective circuit breaker with a bi-metal that is located between an unbalance motor and a frequency converter is often activated by mistake by the harmonics that are generated by the frequency converter and therefore this protection device is not useful!

4.2.3 Connexion Cable

AViTEQ		Im Bollthalf 16 D-65736 Hattersheim/Main Tel.: +49(0)6145503-0 www.aviteq.de	
Unwuchtmotor/Unbalanced motor/Moteur a balourds			
Type	Volt	Hz	
FS	C.F./kW	Ph. 3	RPM
Max. Amb. °C	Prot. IP66	Ser. n°	Duty S1
Ex II LCLIE 07 ATEX 6031 X			
T3 ID A21 IP66 T	°C	T4 ID A21 IP66 T	°C
Amp.	A/n	Amp.	A/n
Cos. φ	A/n	Cos. φ	A/n
kW in.	t _e	kW in.	t _e
IEC80034 VDE0530 Made in E.U.		Ins. C1 F Connect	

Choose the connexion cables according to the nominal current (observe information on the type label). The outer diameter of the cable must suit the cable gland at the terminal box.

For the mains connexion, you should use a multi-wire flexible rubber cable that refers to the appropriate requirements that are valid for areas with explosive gas atmospheres (zone 1 or 2) or areas with the presence of combustible dust (zone 21 or 22).

Motor protection

For sizes "eUVB..." and larger, the unbalance motor is equipped with a triple PTC thermistor. If you want to use the unbalance motor without the PTC thermistor, a four-wire cable is sufficient. When using the triple PTC thermistor, you need at least a six-wire cable. In this case, we recommend that you use a standard seven-wire cable. One of the wires remains unconnected.

Special installation remarks

To avoid abrasion on the cables, the wiring should be fixed except for the last 0.5 m leading to the unbalance motor. This part of the cables must sag freely such that the vibration movement does not cause tensile stresses on the cables.



*Short circuits and electric shock may result if insulation is damaged by rubbing! Connecting cables must **never** come in contact with vibrating parts – otherwise, the insulation may get damaged. Run the cables in a way that excludes this danger!*



If the connexion cable goes into resonance during operation, which leads to excessive swinging of the cable, altering the length changes the resonance and makes the cable to move normal. Shorten or extend the cable in this case!

4.2.4 Connexion Diagram

AViTEQ unbalance motors are suitable for continuous operation (operating mode S1).

If no braking unit or frequency converter is used, the unbalance motor(s) must be connected and protected as shown in figure 4.2 (...see the next chapter 4.2.5 for a terminal diagram).

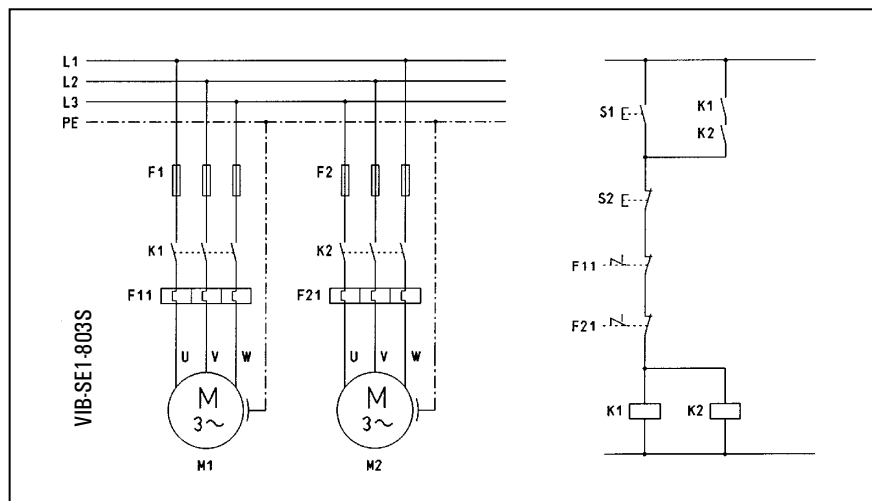

Figure 4.2 Wiring diagram for direct connexion of two interlocking unbalance motors, without PTC thermistor

4.2.5 Terminal Connexions inside the Terminal Box

- ☞ Open the cover of the terminal box by removing the four fixing screws and remove the foam rubber frames - they dampen cable vibrations inside the terminal box (...some motor types have only one foam rubber frame).
- ☞ Remove the included nuts (6x), jumpers (3x), lock washers (6x) and washers (6x) from the pouch which you need to mount the lugs. You will also find a leaflet that shows the possible terminal connexions.

AViTEQ		Im Balthasar 16 D-65735 Hattersheim/Main Tel.: +49 (0) 6145 503-0 www.aviteq.de	
Unbalance motor / Unbalanced motor / Moteur a balourd			
Type	Vol11		Hz
FS	C.F.M	Ph. 3	RPM
Max. Amb. °C	Prot. IP66	Ser. n°	
CE 0722 II 20.D Exe II LCIE 07 ATEX 6031 X			
T3 ID A21 IP66 T °C	T4 ID A21 IP66 T °C		
Amp.	Amp.		
Cos. φ	C.F.M		
KW in.	KW in.		
IEE60034	VDE0530	Ins. Cl. F Connect	
Made in E.U.			

The terminal allocation depends on the motor type and whether or not the PTC thermistor is to be connected. There is also the choice between star-connexion (high voltage) or delta-connexion (low voltage).

Look up the appropriate connexion designator in the "Connect" line of the motor's type label. If this information is missing, use the data in the accompanying special data sheet for the circuit.



The leading-out wires are always wired in the direction of the rotating field. This simplifies cable connexion for a given direction of rotation.

*All unbalance motors must be operated by using all three phases. A two-phase operation is **not** allowed!*

Select the correct scheme and connect according to the appropriate diagram. Always use ring-shaped lugs for connecting the wires.

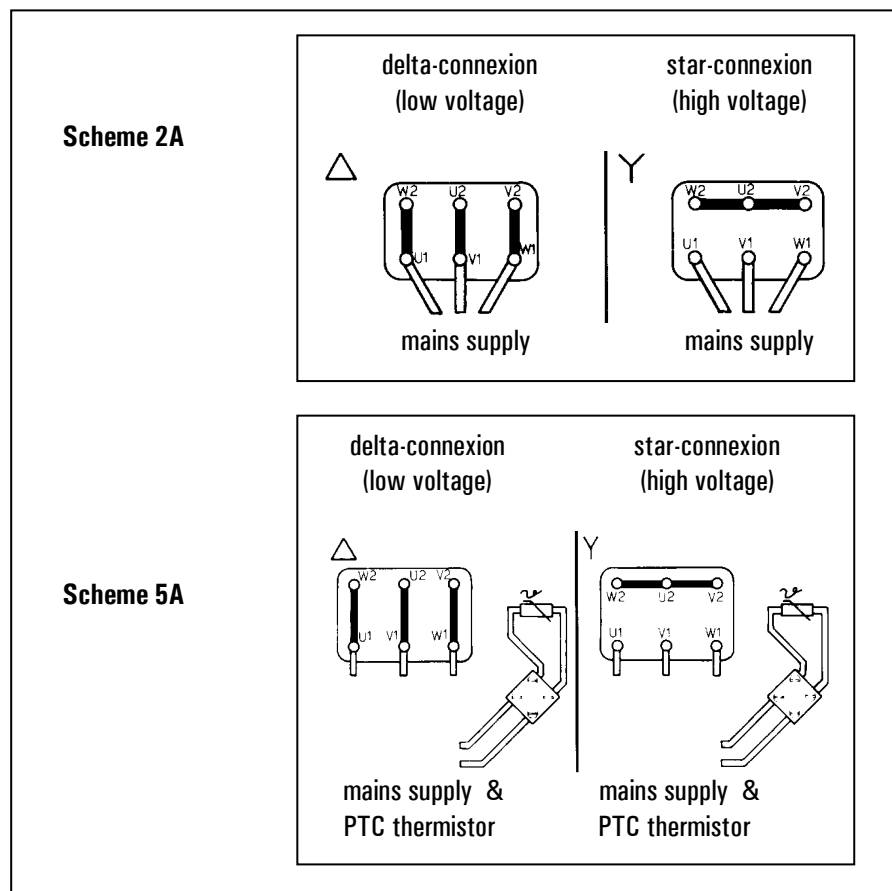
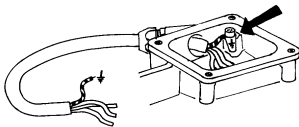

Figure 4.3 Connection schemes for wiring in the terminal box (..if included, observe the special data sheet which may accompany the motor!)

When tightening the nuts in the terminal box of the unbalance motor, please observe the following torques:

Screw size	Screw tightening torques [Nm]
M 4	1,2
M 5	2,0
M 6	3,0

Table 4.4 Screw tightening torques for brass nuts and screws



- ☞ In any case, you should connect the protective earth conductor via the protective earth terminal that is located inside of the terminal box.
- ☞ Put the foam rubber cushions around the terminal block.
- ☞ Close the terminal box by screwing the cover back on. Ensure that the o-ring sealing under the cover is in its correct position!



For a better adhesion of the o-ring sealing of the cover of the terminal box we recommend to use some silicone grease!

5 Commissioning

5.1 Adjusting the Centrifugal Force



Touching the rotating centrifugal weights may be perilous and lead to serious injuries! Before removing the protective hoods, disconnect the unbalance motor from the mains supply and secure it against unintended reconexion. Verify that no voltage is present!

Danger of crushing! Your fingers may get crushed when handling the centrifugal weights! The centrifugal weights should be able to rotate easily while located in there lower centre of gravity position!



Always adjust the centrifugal weights on each side of the unbalance motor's shaft with the same setting (%-value). Otherwise non-uniform oscillations of the vibration (conveyor) device are possible.

Depending on the size and the oscillation frequency of the unbalance motor you will find different kinds of designs for the centrifugal weights and the possibility to adjust them. Orientate yourself by observing the following figures and proceed as follows:

- ☞ First remove both protective hoods by taking out the appropriate fastening screws.

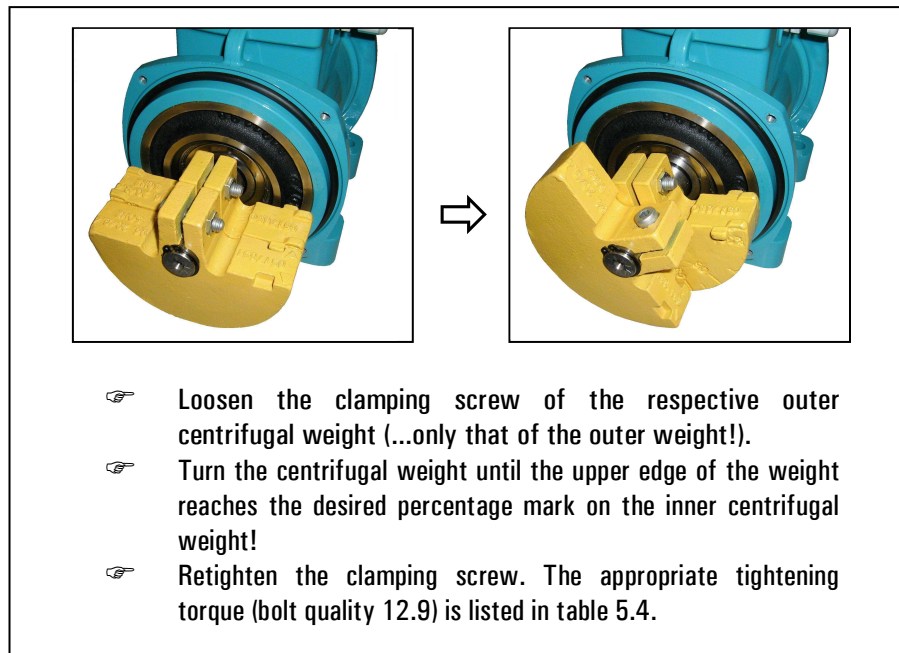

Figure 5.1 Adjustment of the centrifugal weights, using the eUVD 4X... as an example



Damage of the unbalance motor and the risk of injuries with the types eUVE 7,7Y-A1; eUVE 7X-A1 and eUVE 3W-A1 possible! With these types the protective hoods are part of the bearing shield construction and are used for fixing the bearing shields. Depending on the mounting position we recommend to fix the bearing shield again after removing the protective hood by screwing in the appropriate fixing screws.

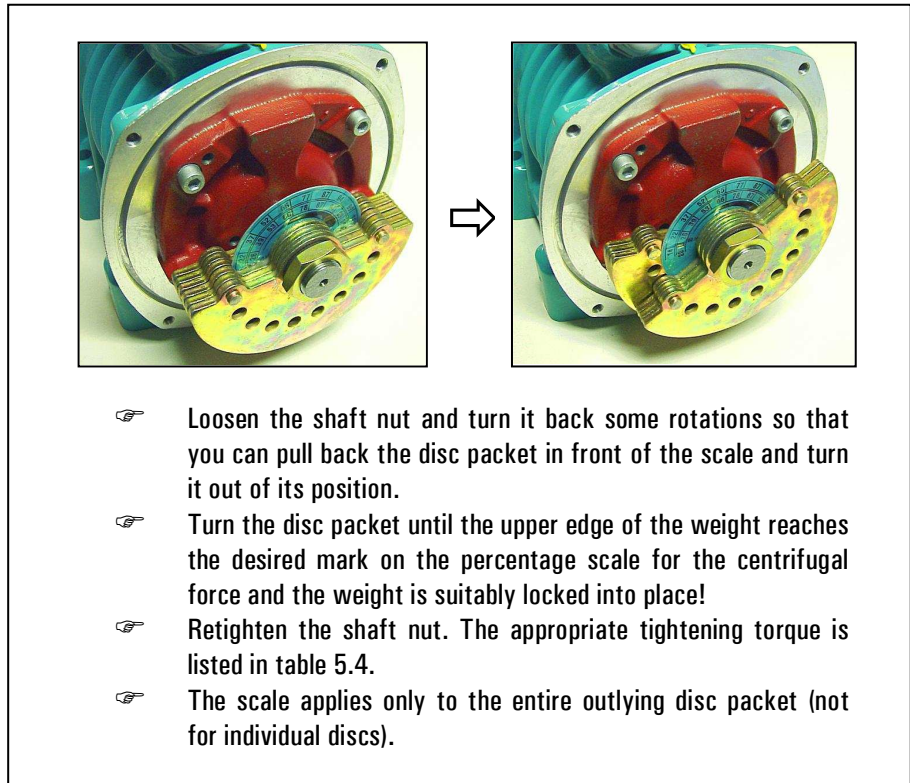

Figure 5.2 Adjustment of the segment centrifugal weights, using the UVE 11Y... as an example

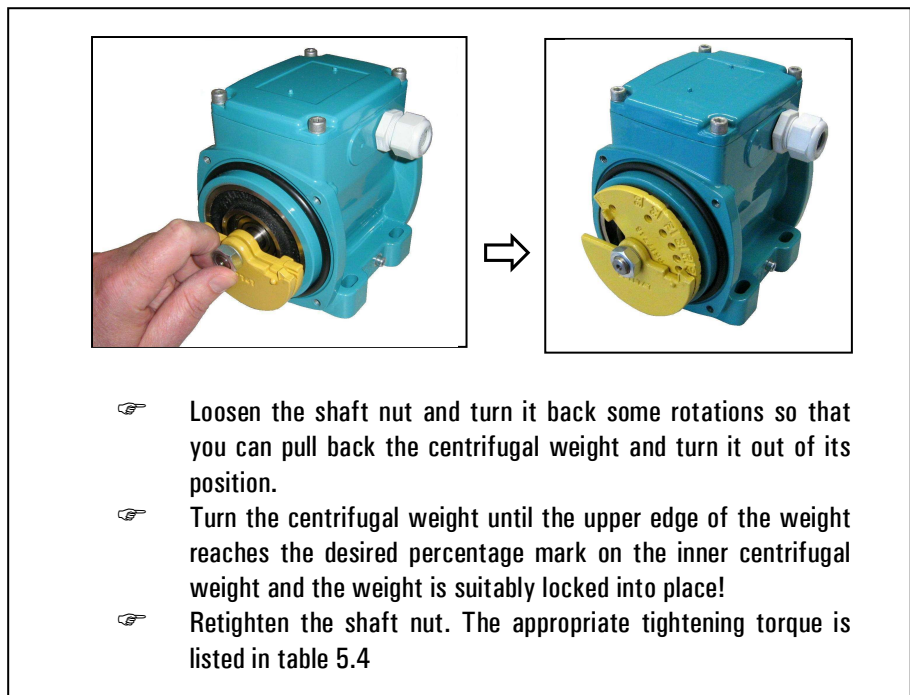

Figure 5.3 Adjustment of the centrifugal weights, using the UVB 0.3X... as an example

Screw size	Screw tightening torque	Screw size	Screw tightening torque
Clamping screw	Bolt quality 12.9 [Nm]	Shaft nut	[Nm]
M 8	36	M13x1,0	28
M10	72	M15x1,0	45
M12	125	M20x1,0	90
M14	200	M25x1,5	150
		M30x1,5	300
		M45x1,5	450

Table 5.4 Screw tightening torques for clamping screws and shaft nuts

- ☞ Check the sealing surfaces and the sealings of the protective hoods. These must to be without damage.
- ☞ Slide on the protective hoods and put in and tighten the screws again. The appropriate tightening torque is listed in table 4.1 on page 26.

5.2 First Commissioning

Prior to the first commissioning, you must verify that all motor attachment screws have been tightened with their corresponding torque and that all installation works have been carried out.



DANGER!

Inadequate installation may cause the unbalance motor to fall down possibly causing injuries. Ensure that the unbalance motor is bolted on tight to the working unit!

Once again check the electrical feed to the unbalance motor and ensure that the motor will only be operated with the current, voltage, and frequency stated on the motor's type label.

5.2.1 Single Drive

For single drives, the direction of rotation of the unbalance motor may be chosen freely.

5.2.2 Double Drive

If the unbalance motors are installed in pairs, the direction of rotation has to be set depending on the desired oscillation movement. For linear oscillations, the unbalance motors must rotate in opposite directions. For spiral oscillations (helical oscillations), the unbalance motors must rotate in the same direction.

Briefly (max. 2 seconds) switch on the unbalance motors to check the direction of rotation. For this purpose, remove the upper protective hood at each unbalance motor.



ATTENTION!

Damage of the unbalance motor and the risk of injuries with the types eUVE 7,7Y-A1; eUVE 7X-A1 and eUVE 3W-A1 possible! With these types the protective hoods are part of the bearing shield construction and are used for fixing the bearing shields. Therefore only the upper protective hood is to be removed to avoid the motor shaft from getting loose!

We recommend to fix the bearing shield temporarily after removing the protective hood by screwing in the appropriate fixing screws. Please mount the protective hood again after checking the sense of rotation.

To verify the direction of rotation, it is sufficient to switch the motor on and immediately off again.



DANGER!

Touching the rotating centrifugal weights may be perilous and lead to serious injuries! Ensure that you and others stay far enough away and that no objects can intrude into the area near the centrifugal weights!

Changing the direction of rotation

- ☞ If the direction of rotation on one of the motors is incorrect, swap two or three phases on the connexion cable leading to the unbalance motor.



DANGER!





Before swapping phases, disconnect all power to the unbalance motor and secure it against unintentional reconnection. Check that no voltages are present before you swap!



ATTENTION!

Always ensure that both unbalance motors rotate in the correct direction. Even brief operation with a wrong direction of rotation may lead to major damage on the vibration (conveyor) device.

5.2.3 Final Check

-  Finally please check that both protective hoods are properly installed, further that all of the fixing screws of the protective hoods are tightened and the terminal box is closed properly.
-  Verify that the combination consisting of unbalance motor(s) and vibration (conveyor) device works as intended. If required, correct the adjustment of the centrifugal weights.
-  In case of double drives, make sure that both unbalance motors work with the correct direction of rotation!
-  Make certain that no loose parts are in contact with the unbalance motor or vibration (conveyor) device. Malfunctions, noise and/or damage may otherwise result.
-  Check the current draw of all unbalance motors. If the value exceeds the value that is shown on the type label of the unbalance motor, reduce the centrifugal force for lowering the current draw and contact AViTEQ. After reducing the centrifugal force check once more, if the current draw is lower than the value shown on the type label.



DANGER!

Short circuit or danger of electrocution during the following measurements! Observe the safety regulations when measuring voltage-carrying components! Take appropriate measures to prevent contact with voltage-carrying components!



ATTENTION!

It is totally prohibited that the current consumption of the unbalance motor exceeds the value of the nominal current specified on the type label, because this may lead to inadmissible temperatures.

6 Maintenance



DANGER!

Before carrying out any maintenance work, the unbalance motor must be disconnected from mains and protected against reconnecting. Check that no voltage is present! Further check, if the surface temperature is less than +50°C, otherwise the surface temperature may lead to burns of the skin!

6.1 Regular Checks

We recommend the following checks in regular intervals as shown below:

Inspection intervals	Checks
2 operating hours after the first commissioning	<ul style="list-style-type: none"> - Check screw connexions (working unit/drive) - Check, if connexion cable doesn't swing - Check, if connexion cable shows visible damages - Check noise development
24 operating hours after the first commissioning	<ul style="list-style-type: none"> - Check screw connexions (working unit/drive) - Check, if connexion cable doesn't swing - Check, if connexion cable shows visible damages - Check noise development - Check the condition of the protective hoods and the cover of the terminal box
Weekly	<ul style="list-style-type: none"> - Check, if connexion cable doesn't swing - Check, if connexion cable shows visible damages - Check noise development
Monthly	<ul style="list-style-type: none"> - Check screw connexions (working unit/drive)
Half-yearly	<ul style="list-style-type: none"> - Check the condition of the protective hoods and the cover of the terminal box

Table 6-1 Regular checks

6.2 Replacing the Sealings



ATTENTION!

If the unbalance motor is operated in areas with the presence of combustible dust (zone 21 or 22, the sealing (o-ring) of the cover of the terminal box and the sealings of the protective hoods must be replaced every 2 years. If damages are visible the sealings must be replaced immediately!



DANGER!

Touching the rotating centrifugal weights may be perilous and lead to serious injuries! Before removing the protective hoods, disconnect the unbalance motor from the mains supply and secure it against unintended reconnexion. Verify that no voltage is present!

For replacing the sealings first remove the cover of the terminal box and both protective hoods at the unbalance motor. Then replace the appropriate sealings. Afterwards mount the cover of the terminal box and the protective hoods again.



NOTE

Only use original sealings that you can order from AVITEQ. For a better adhesion of the o-ring sealings of the cover of the terminal box and the protective hoods we recommend to use some silicone grease!

6.3 Bearing Lubrication

The motor bearings are permanently lubricated. Unbalance motors, type eUVE... and larger, which have lubrication nipples, can be relubricated. The appropriate lubrication nipples (type: DIN 71412-AM...) are located on the outer housing of the motors and are normally covered by plastic caps.

Systematical relubrication extends the life cycle of the bearings of the unbalance motors. The necessary amount of grease for relubrication and the recommended lubricant that is used by AViTEQ is shown in the following tables.

Unbalance motor types	Bearing type	Amount of grease for initial lubrication	Bearing replacement interval without re-lubrication	Re-lubrication interval	Number of allowed relubrications	Amount of grease for re-lubrication	Lubricant	Bearing replacement interval with re-lubrication
eUVB 1Y-A1 eUVB 0,3X-A1	6302 2ZR.C3	-	-	-	No relubrication possible	-	-	-
eUVB 1,9Y-A1 eUVB 0,7X-A1	6302 2ZR.C3	-	-	-	No relubrication possible	-	-	-
eUVC 3Y-A1 eUVC 1,5X-A1 eUVC 2,1X-A1	6304 2ZR.C3	-	-	-	No relubrication possible	-	-	-
eUVD 5Y-A1 eUVD 4X-A1 eUVD 5,4X-A1	6306 2ZR.C3	-	-	-	No relubrication possible	-	-	-
eUVE 7,7Y-A1	NJ305E-TVP2.C4.BL	8 g	4.000 h	-	No relubrication possible	-	ISOFLEX NBU 15	-
eUVE 7X-A1 eUVE 3W-A1	NJ305E-TVP2.C4.BL	8 g 8 g	8.000 h 24.000 h	-	No relubrication possible	-	STABURAGS NBU 8EP	-
eUVE 7,7Y-A2 eUVE 7X-A2 eUVE 3W-A2	6309 2Z C4 WT	-	-	-	No relubrication possible	-	-	-
eUVE 11Y-A1	NJ306E-TVP2.C4.BL	12 g	2.650 h	800 h	5	6 g	ISOFLEX NBU 15	4.000 h
eUVE 10X-A1 eUVE 5W-A1	NJ306E-TVP2.C4.BL	12 g 12 g	6.500 h 16.000 h	2.000 h 4.800 h	5 5	5 g 5 g	STABURAGS NBU 8EP	10.000 h 24.000 h
eUVF 20Y-A1	NJ2308E-TVP2.C4.BL	30 g	4.000 h	1.200 h	5	15 g	ISOFLEX NBU 15	6.000 h
eUVF 18X-A1	NJ2308E-TVP2.C4.BL	30 g	13.200 h	4.000 h	5	12 g	STABURAGS NBU 8EP	20.000 h
eUVF 11W-A1	NJ308E-TVP2.C4.BL	30 g	16.000 h	4.800 h	5	12 g	STABURAGS NBU 8EP	24.000 h
eUVF 24X-A1	NJ2309E-TVP2.C4.BL	35 g	8.000 h	2.400 h	5	14 g	STABURAGS NBU 8EP	12.000 h
eUVF 16W-A1	NJ309E-TVP2.C4.BL	30 g	16.000 h	4.800 h	5	12 g	STABURAGS NBU 8EP	24.000 h
eUVG 38X-A1	NJ2311E-TVP2.C4.BL	40 g	6.500 h	1.250 h	8	16 g	STABURAGS NBU 8EP	10.000 h

Table 6-1 (Part 1) Relubrication intervals and amounts of grease for new lubrication and relubrication for normal operating conditions

Unbalance motor types	Bearing type	Amount of grease for initial lubrication	Bearing replacement interval <u>without</u> re-lubrication	Re-lubrication interval	Number of allowed relubrications	Amount of grease for re-lubrication	Lubricant	Bearing replacement interval <u>with</u> re-lubrication
eUVG 21W-A1	NJ311E-TVP2.C4.BL	32 g	16.000 h	3.000 h	8	12 g	STABURAGS NBU 8EP	24.000 h
eUVH 49X-A1	NJ2313E-TVP2.C4.BL	80 g	5.250 h	1.000 h	8	32 g	STABURAGS NBU 8EP	8.000 h
eUVH 38W-A1	NJ313E-TVP2.C4.BL	60 g	6.500 h	1.250 h	8	24 g	STABURAGS NBU 8EP	10.000 h
eUVN 83X-A1	NJ2318E-	180 g	5.250 h	800 h	10	75 g	STABURAGS	8.000 h
eUVN 95W-A1	M1A.C4.BL	180 g	6.500 h	1.000 h	10	75 g	NBU 8EP	10.000 h

Table 6-1 (Part 2) Relubrication intervals and amounts of grease for new lubrication and relubrication for normal operating conditions



ATTENTION!

Please observe the information about the lubricants that are valid for ambient temperatures up to +40°C! If you want to use a lubricant from an other manufacturer, please check that the lubricant is equal to the lubricant AViTEQ is using. It isn't allowed to mix synthetic lubricants and lubricants that are based on mineral oil, because this may lead to a reduction of the life cycle of the bearings and further to an early malfunction.

Avoid excessive lubrication! Excessive lubrication may lead to early decomposition of the grease and may cause overheating of the bearing. We recommend to carry out the relubrication in two single steps with a time distance of some 8 operating hours.



NOTE

The recommended bearing replacement intervals are valid for a centrifugal force setting of 100%. With a reduced centrifugal force setting the bearing replacement interval will increase. Ask us in case of need.

The number of allowed relubrications and the bearing replacement intervals are recommended by AViTEQ. In the case of heavy-duty operating conditions (e.g. ambient temperatures above +40°C) shorter relubrication intervals might be recommended.

Once the number of relubrications specified in the table 6-1 is reached, the unbalance drive has to be sent to AViTEQ, 65795 Hattersheim-Eddersheim, Germany, or a service base to have its bearings replaced. Further relubrication on site would overfill the bearing with solid old grease and lead to damaging the bearings.



NOTE

After relubrication it is possible that the unbalance drive draws a higher current and gets hotter for a short period until the grease is distributed uniformly inside of the bearing.

Irrespective of the number of operating hours we recommend to replace the grease after a period of 3 years if no relubrication has been carried out. Reason for this is the ageing of the lubricant.



NOTE

STABURAGS NBU 8EP and ISOFLEX NBU 15 are lubricants produced by the company Klueber, whose address can be asked for from AViTEQ Vibrationstechnik GmbH if needed. If you want to use a lubricant that is produced by another manufacturer, please clarify with your supplier if the lubricant is equal to the lubricant that is used by AViTEQ.



NOTE

For disposal of the lubricant, please observe the appropriate specifications released by the lubricant producer and the valid local environmental regulations. If needed ask the manufacturer about the composition of the lubricant.

6.4 Cleaning

Depending on the environmental condition and the properties of the material transported, the components of the unbalance motor, in particular the working unit, will be subject to varying degrees of contamination.

Check the contamination level on regular basis. Initially, check on a weekly basis, thereafter check in intervals that you determine based on the requirements.

If the contamination is significant enough to impair the throughput, or there is a layer of dirt on the unbalance motor that is thicker than 5 mm, it must be cleaned. As cleaning methods, alongside mechanical methods (hand brush e.g.), pressurized air and water with and without chemical cleansing agents are allowed.

Proceed thereby as follows:

- ☞ Switch off the power to the drive before any cleaning operation!
- ☞ Select the appropriate method! If applicable, follow the guidelines for the use of pressurized air, water and cleaning solvents that apply to the installation site! Also observe the degree of protection (IP66) and take appropriate steps to avoid water intrusion into the terminal box.
- ☞ Only use cleaning solvents with a pH value of 7 or greater!
- ☞ Do not use cleaning solvents containing chlorine!
- ☞ When cleaning with compressed air, observe any in-house regulations regarding dust!



ATTENTION!

Detachment of paintwork and contamination of the transported material! Do not use aggressive agents that could damage the paintwork! In the food processing industry, only permitted cleaning agents and solvents may be used. Do not use cleaning agents that may attack the plastic insulation of cables and cable glands!

- ☞ Remove all residues of transported material and cleaning agent after cleaning!

6.5 Repairs

In the event of damage, please send the unbalance motor back to AViTEQ Vibrationstechnik GmbH, 65795 Hattersheim-Eddersheim, Germany for being repaired. We recommend not to carry out self-repairs.



ATTENTION!

Danger of damage and injuries when disassembling the unbalance motor! Do not attempt to make any repairs yourself! Don't disassemble the unbalance motor for repair purposes, even if it is disconnected from the mains supply.

*Self-repairs are **not** allowed if the unbalance motor is operated in areas with explosive gas atmospheres (zone 1 or 2) or in areas with the presence of combustible dust (zone 21 or 22). The only work that is allowed in this case is the attachment of the unbalance motor(s), the adjustment of the centrifugal force by removing the protective hoods, the electrical connexion by opening the cover of the terminal box, the relubrication of the bearings, and the replacement of the sealing (o-ring) of the cover of the terminal box and the sealings of the protective hoods.*

In the case of a device defect, send the entire unbalance motor to AViTEQ Vibrationstechnik GmbH, 65795 Hattersheim-Eddersheim, Germany. We will take appropriate steps for fastest repair or replacement possible!

7 Troubleshooting

In the following table you will find information regarding possible faults which could occur during installation or during operation.

	Fault	Cause(s)	Remedy
①	Drive does not function	No mains voltage	Check fuse(s) and the supply line(s)
		Unbalance motor damaged	Please send the unit to AViTEQ Vibrationstechnik GmbH, we will check and if possible repair the unbalance motor or replace the drive by a new one
②	Excessive heat-up of the unbalance motor, PTC thermistor acts	Power input of the unbalance motor inadmissibly high, observe point ④	Clear the reason
		Bearing damaged	Please send the unit to AViTEQ Vibrationstechnik GmbH, we will check and if possible repair the unbalance motor or replace the drive by a new one
③	Release of the motor-protective circuit breaker	Motor-protective circuit breaker has the wrong adjustment	Observe the current shown on the type label of the unbalance motor and alter the adjustment on the motor-protective circuit breaker.
		Power input of the unbalance motor inadmissibly high	Observe point ④.
④	Power input of the unbalance motor inadmissibly high	Winding damaged	Please send the unit to AViTEQ Vibrationstechnik GmbH, we will check and if possible repair the unbalance motor or replace the drive by a new one
		Excessive lubrication of the bearings	May appear temporarily after relubrication, operate drive for some 10 minutes, then let the drive cool down, repeat procedure 4 up to 5 times
⑤	Increased noises at the unbalance motor	Bearing(s) damaged	Please send the unit to AViTEQ Vibrationstechnik GmbH, we will check and if possible repair the unbalance motor or replace the drive by a new one
		Mounting screws/bolts have come loose	Tighten mounting screws with the appropriate tightening torque according to the values that are shown in the table 4.1
		Loose parts are colliding with the unbalance motor and/or the working unit	Remove or fix loose parts immediately
⑥	No synchronous working with a double drive	Malfunction of one of the unbalance motors	Check mains supply, clear the reason and solve it
		Two-phase operation	Check fuse(s) and the supply line(s), clear the reason for the loss of the phase and solve it, consult AViTEQ Vibrationstechnik GmbH in case of need
		Sense of rotation of both unbalance motors is similar	Swap phases
		Shaft of the unbalance motor is blocked or cannot rotate freely	Please send the unit to AViTEQ Vibrationstechnik GmbH, we will check and if possible repair the unbalance motor or replace the drive by a new one
⑦	Motor foot broken	Mounting screws/bolts have come loose	Please send the unit to AViTEQ Vibrationstechnik GmbH, if possible we will repair the unbalance motor or replace the drive by a new one
		Contact surfaces at the motor feet uneven (manufacturing or design error)	Please send the unbalance motor to AViTEQ, if possible we will repair it or replace the drive by a new one, take care for an even contact surface
		Foreign object(s) (grease, paint) at the contact surfaces at the motor feet	Please send the unbalance motor to AViTEQ, if possible we will repair it or replace the drive by a new one, take care for a clean contact surface

Table 7-1 Fault, Causes, and Remedies



NOTE

Consult us, however, prior to performing error rectification measures to avoid possible damages or accidents.

The faults listed in the table 7-1 mainly refer to the unbalance motor. Further faults, caused by the controller, can be found in the appropriate operating manual.

8 Index

- Address** 8
 - Adjusting the centrifugal force 33ff.
- Blind plug** 21
 - Braking unit 10
- Cable gland** 21
 - Centre of gravity 16
 - Centrifugal weight(s) 21
 - Checks, regular 38
 - Cleaning 42
 - Climate environments 13
 - Commissioning 33ff., 36
 - Condensation 16
 - Conditions of delivery, domestic and abroad 11
 - Conditions of warranty 11
 - Connexion cable 29
 - Connexion diagram 30
 - Copyright 8
- Declaration of Incorporation** 47
 - Delta-connexion 31
 - Declaration of conformity 46
 - Device specification 19
 - Direction of rotation 36f.
 - Direction of the rotating field 31
 - Disposal 17
 - Double drive 19f., 36
- EC-Directives** 15
 - Elevation, allowed 13
 - Environmental temperature, allowed 13
 - Extent of delivery 17
- Frequency converter** 6, 28, 29
- Grounding screw** 21
- Housing sizes** 22
 - Hybrid-mixtures 7, 13
- Installation** 25ff.
 - Installation personnel 13
 - Insulation class 14
 - Intended use 2
- Life cycle of the bearings** 39f.
 - Lubricant(s) 39f.
 - Lubrication nipple 39
- Mains connexion** 30
 - Maintenance 38
 - Materials used in the unit(s) 18
 - Mounting holes dimensions 22f.
 - Motor protection 29
- Number of operation cycles, allowed** 6
 - Number of poles 22
- Operating personnel** 13
 - Operative range 13
 - Overload protection 29
- Packing materials** 17
 - Product liability 11
 - Protective earth terminal 32
 - Protective hood 21
 - PTC thermistor, triple 14
- Relubrication** 39ff.
 - Relubrication intervals 39f.
 - Repairs 43
 - Responsibilities of the operator 15
 - Returning the device 18
 - Revision date 10
 - Ring bolt(s) 21
- Safety remarks** 3ff.
 - Screw tightening torques 26, 32, 35
 - Sealing(s) 38
 - Single drive 19, 36
 - Sound pressure level 24
 - Star-connexion 31
 - Storage 16
 - Surface temperature(s) 4, 24
- Terminal box** 21
 - Terminal connexion(s) 30
 - Transport 16
 - Troubleshooting 44
 - Type designation 22
- Unbalance motor** 10
- Vibration (conveyor) unit** 10
- Warranty** 11
 - Warranty exclusions 11
 - Welding work 5
 - Working unit 10

Declaration of Conformity

according to Appendix X B of the EC Directive 94/9/EC relating to equipment and protective systems for use in explosive atmospheres

The Manufacturer...

AViTEQ Vibrationstechnik GmbH
Im Gotthelf 16
65795 Hattersheim-Eddersheim
Germany

declares that the unbalance motors of the series...

eUV...-A_

are in conformance with the following European directive...

94/ 9/EC

Directive relating to equipment and protective systems for use in explosive atmospheres

and are classified as electrical apparatus of the equipment group II and therefore can be operated according to the following definition



LCIE 07 ATEX 6031 X
II 2 G Ex e II T3 and/or T4
II 2 D Ex tD A21 IP66 T ... °C¹

The conformance of the products with the European Directive is demonstrated through full observation of the following harmonized European and International Standards:

EN 60079-0
EN 61241-0

EN 60079-7
EN 61241-1

Full technical documentation is available. The operating manual for the devices is in hand. The CE symbol has been included .

AViTEQ Vibrationstechnik GmbH possess a certificated quality system for manufacturing unbalance motors that complies with the requirements of the directive 94/9/EG, Appendix IV. The appropriate certification number reads: CESI 01 ATEX 018 Q.

The safety notes in the operating manual and the intended use must be observed! This declaration certifies conformance with the specified standards and directive . It does not, however, include a guarantee of characteristics.

Hattersheim-Eddersheim, 08th of April 2008

Legally binding signature:

i.A. Beilfuss (Product Manager for Unbalance Motors)

Declaration of Incorporation

(Translation of the original Declaration of Incorporation)

according to Appendix II, Part 1, Section B of the EC Directive 2006/42/EC for Machines

The manufacturer...

**AViTEQ Vibrationstechnik GmbH
Im Gotthelf 16
65795 Hattersheim-Eddersheim
Germany**

declares that the drives (unbalance motors) of the series...

eUV...-A_

comply with the requirements of the following European Directive:

2006/42/EC Directive for Machines

and according to Article 2 Point g), these are partly completed machinery which are exclusively intended for the installation in or for the assembly with another machine or equipment.

The special technical documents according to Appendix VII Part B have been produced. Mr. **Adrian Beilfuss** is authorised to compile these special technical documents according to Appendix VII Part B and to transmit these on request in electronic form to the responsible national authorities. The associated address is: **AViTEQ Vibrationstechnik GmbH, Mr. Adrian Beilfuss, Im Gotthelf 16, 65795 Hattersheim-Eddersheim, Germany.**

The following general health and safety requirements according to Appendix I of this Directive are applicable and have been complied with:

**1.1.1; 1.1.2; 1.1.3; 1.1.5;
1.3.1; 1.3.2; 1.3.3; 1.3.4; 1.3.6; 1.3.7;
1.4.1;
1.5.1; 1.5.2; 1.5.6; 1.5.7;
1.7.3; 1.7.4; 1.7.4.1; 1.7.4.2 and 1.7.4.3.**

The conformity of the products with the European Directive is also proven by compliance with the following harmonised and (inter)national standards and requirements:

**EN ISO 12100-1 / ...-2
EN 60034-1
EN 60529**

According to Article 2 Point g) of the Machines Directive 2006/42/EC, the drives are partly completed machinery. Installation instructions according to Appendix VI must be produced for and supplied with these partly completed machinery. Due to the requirements arising from other also applicable EC Directives, a complete operating manual has been produced. This is an integral part of the product. A separate installation manual therefore does not exist. Instead, the description of the installation is part of the operating manual and must be observed accordingly.

It is not permitted to start using the drive until it has been ensured that the machine in which the drive is installed complies with the provisions of the Machines Directive 2006/42/EC.

Strictly observe the safety instructions and the information about proper use in the supplied operating manual.

Hattersheim-Eddersheim, 30th of March 2010

Legally binding signature:



i.V. Beilfuss (Product Manager for Unbalance Motors)

AVITEQ Vibrationstechnik GmbH
Im Gotthelf 16
65795 Hattersheim-Eddersheim
Germany

Phone +49 / 61 45 / 5 03 - 0
Fax +49 / 61 45 / 5 03 - 2 00
Fax +49 / 61 45 / 5 03 - 112 (Service-Hotline)
E-Mail service@aviteq.de

www.aviteq.de



VIB 12.96 / 01-2010 EN (BE) - 58149