

## Rotation Speed Monitor Type AI-Ni 7

### Technical Data



#### General

The AI-Ni 7 is for attachment to the shaft end of large machines or motors to monitor their running up, reaching the nominal speed and stopping at braking. Monitoring of conveyor belts is possible by rolling wheels.

The AI-Ni 7 is the successor of the proven AI-Ni 5.

Its dimensions at clutch flange and size have been maintained from its predecessor and the function principle is compatible. With respect to the lower switching power the AI-Ni 7 is appropriate for monitoring slow-down, revolution and conveyor belts.

As an advantage the AI-Ni 7 features a digital adjustment of the switching speed (r.p.m.) by code switches. The adjustment range is from

120 r.p.m. up to 6000 r.p.m. (2-100 revolutions per second) in steps of 60 r.p.m. and can be set independently for left and right turning.

#### Function Principle

When the shaft is turned a stepper motor induces the supply power for the signal processing circuits and the signal voltages for determination of revolution and direction.

When the speed selected by the code switches is reached relay 1 switches at left turning and relay 2 switches at right turning.

#### Switching Speed

For adjustment of the switching speed the coding switches, two for each turning direction, are to be set by a small screw driver.

The digits 02 to 99 can be adjusted directly, the adjustment 00 is interpreted to 100 revolutions per seconds.

The switching hysteresis is 30 - 60 r.p.m. (0,5 - 1 revolutions per second).

### Switching Performance

The switching performance is determined by the contacts of the **monostable** relay. The max. values for voltage, current and switching power (resistive) are given in the following table.

### Switching Performance

max. voltage	400V AC	240V DC
max. current	5A	5A
max. switching power	1250VA	150W

### Connecting Ports

The connecting ports are suitable for wires up to 2.5 mm<sup>2</sup>. For insertion of the wires the cage clamp must be opened by the by-packed tool or alternatively by pressing with a suitable screw driver from the front or rear side. The connecting port allocation is given in Fig. 2.

### Warning

Hazardous voltage may appear at the electrical ports even when the device has stopped. Therefore, the power supply must be switched off prior to opening the device. Entrance of humidity into the opened device must be avoided.

---

## Technical Data

---

Supply voltage:	Internally generated
Nominal speed range:	120 to 6.000 r.p.m. (2 to 100 r.p.s.)
Relay contacts:	2 alternators, for left and right turning
Switching performance:	max. 400V AC, 5A, 1250VA max. 240V DC, 5A, 150W (resistive)

---

## Mechanical Data

---

Adaptation:	Pin adapter with plugged elastic clutch
Cable entry:	M20 x 1,5
Housing material:	Glass fibre reinforced plastic; oil, grease and acid resistant
Housing dimensions:	According to fig. 1
Flange diameter:	120 mm
Shaft bearing:	2 ball bearings
Environmental temperature:	Operating -25°...+70°C Storage -40°...+80°C Transport -40°...+80°C
Enclosure:	IP 65

---

## Procurement Data

---

Rotation speed monitor Al-Ni 7	Ident.No.: 243 903
Elastic clutch	Ident.No.: 243 895

---

## Testing and Qualification of the Item

Humidity:	DIN IEC 68-2-30		
	Lower temp.:	+25°C / 97% rel. hum.	
	Upper temp.:	+55°C / 93% rel. hum.	
	Test duration:	6 days	
Vibration:	DIN EN 60 068 -2 -6		
	Frequency:	10 - 150Hz	
	Amplitude:	0,35mm	
	Resp. acceleration:	5g (20 Cycles per axis)	
Shock loads:	DIN EN 60 068 -2 -27		
	Shocktype:	semi-sine	
	Amplitude:	30g	
	Duration:	18ms (3 Shocks per orientation)	
Long term shock loads:		DIN EN 60 068 -2 -29	
	Shocktype:	semi-sine	
	Amplitude:	25g	
	Duration:	6ms (1000 Shocks per orientation)	
Isolation:	DIN / VDE 0435 Part 303		
	Check value:	2kV AC	
Susceptibility:	Conducted susc.:	DIN / EN 50141	10 V
	Radiated susc.:	DIN ENV 50140	10 V/m
	Electrostatic discharge:	DIN EN 61 000-4-8	
		Contact	4 kV
		Air gap	8 kV
	Burst:	DIN EN 61 000-4-4	2 kV
	Surge:	DIN EN 61 000-4-5	
		asymmetrical	4 kV
		symmetrical	2 kV
Emission:	Radiated emission:	DIN EN 55 022	Line B

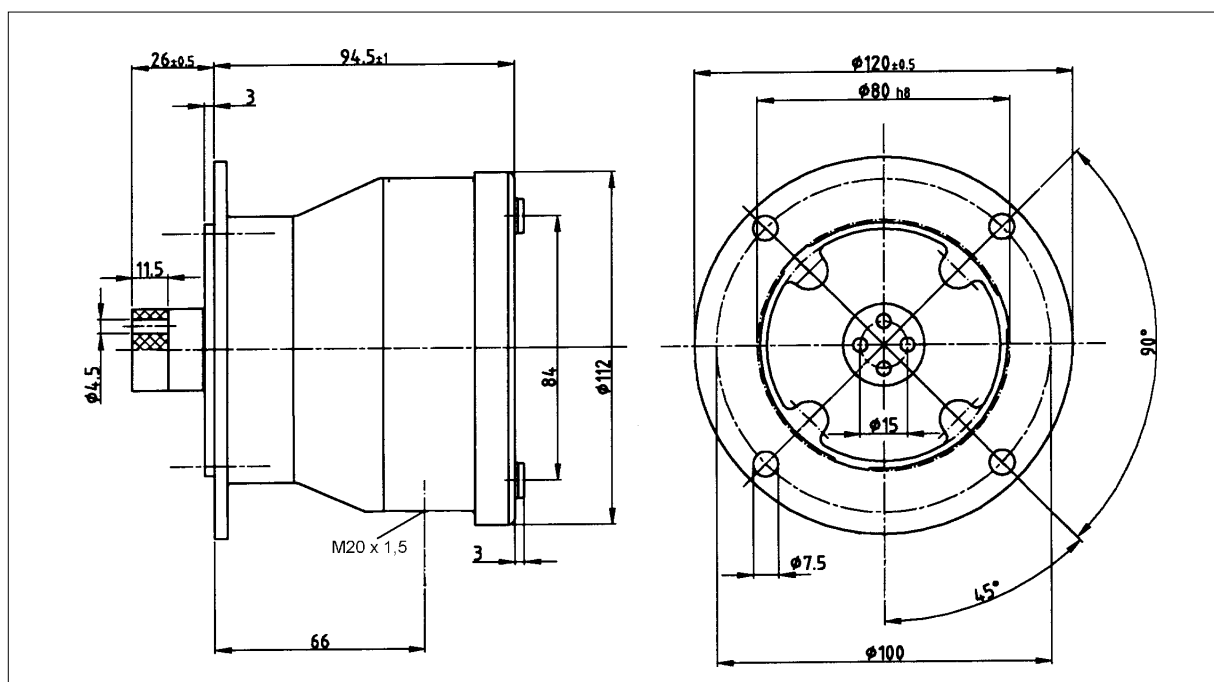
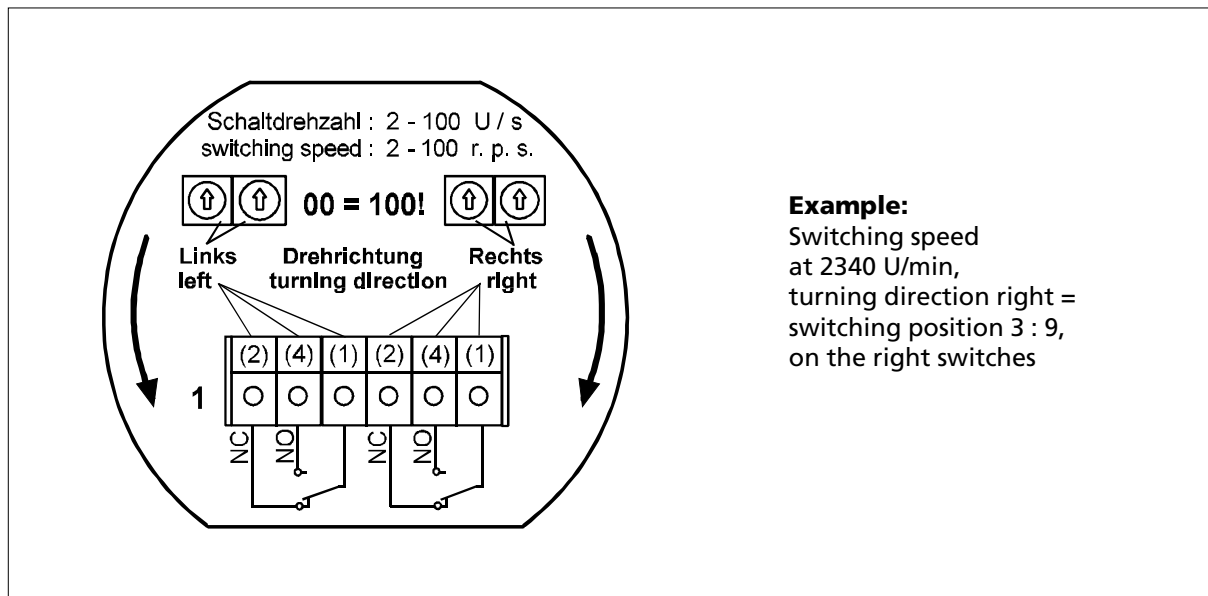

Fig. 1: Dimensions



**Example:**  
 Switching speed  
 at 2340 U/min,  
 turning direction right =  
 switching position 3 : 9,  
 on the right switches

Fig. 2 : Function of the code switches and location of the connecting ports

**Relation of code switches position and switching speed**

Pos.	r.p.s.	r.p.m.	Pos.	r.p.s.	r.p.m.	Pos.	r.p.s.	r.p.m.	Pos.	r.p.s.	r.p.m.	Pos.	r.p.s.	r.p.m.
0 : 1	not	usable	2 : 1	21	1260	4 : 1	41	2460	6 : 1	61	3660	8 : 1	81	4860
0 : 2	2	120	2 : 2	22	1320	4 : 2	42	2520	6 : 2	62	3720	8 : 2	82	4920
0 : 3	3	180	2 : 3	23	1380	4 : 3	43	2580	6 : 3	63	3780	8 : 3	83	4980
0 : 4	4	240	2 : 4	24	1440	4 : 4	44	2640	6 : 4	64	3840	8 : 4	84	5040
0 : 5	5	300	2 : 5	25	1500	4 : 5	45	2700	6 : 5	65	3900	8 : 5	85	5100
0 : 6	6	360	2 : 6	26	1560	4 : 6	46	2760	6 : 6	66	3960	8 : 6	86	5160
0 : 7	7	420	2 : 7	27	1620	4 : 7	47	2820	6 : 7	67	4020	8 : 7	87	5220
0 : 8	8	480	2 : 8	28	1680	4 : 8	48	2880	6 : 8	68	4080	8 : 8	88	5280
0 : 9	9	540	2 : 9	29	1740	4 : 9	49	2940	6 : 9	69	4140	8 : 9	89	5340
1 : 0	10	600	3 : 0	30	1800	5 : 0	50	3000	7 : 0	70	4200	9 : 0	90	5400
1 : 1	11	660	3 : 1	31	1860	5 : 1	51	3060	7 : 1	71	4260	9 : 1	91	5460
1 : 2	12	720	3 : 2	32	1920	5 : 2	52	3120	7 : 2	72	4320	9 : 2	92	5520
1 : 3	13	780	3 : 3	33	1980	5 : 3	53	3180	7 : 3	73	4380	9 : 3	93	5580
1 : 4	14	840	3 : 4	34	2040	5 : 4	54	3240	7 : 4	74	4440	9 : 4	94	5640
1 : 5	15	900	3 : 5	35	2100	5 : 5	55	3300	7 : 5	75	4500	9 : 5	95	5700
1 : 6	16	960	3 : 6	36	2160	5 : 6	56	3360	7 : 6	76	4560	9 : 6	96	5760
1 : 7	17	1020	3 : 7	37	2220	5 : 7	57	3420	7 : 7	77	4620	9 : 7	97	5820
1 : 8	18	1080	3 : 8	38	2280	5 : 8	58	3480	7 : 8	78	4680	9 : 8	98	5880
1 : 9	19	1140	3 : 9	39	2340	5 : 9	59	3540	7 : 9	79	4740	9 : 9	99	5940
2 : 0	20	1200	4 : 0	40	2400	6 : 0	60	3600	8 : 0	80	4800	0 : 0	100	6000