



## **Operating Manual Magnetic Vibrators**

**Series MV ...**

---

## Intended Use

AViTEQ magnetic vibrators in standard version are designed and intended as drives for vibration (conveyor) devices for removing, conveying, distributing, condensing, mixing up, dosing and/or screening of bulk materials **outside of** areas with the risk of explosion by a gas-, a vapour-, a mist- or a dust-air-mixture.

The magnetic vibrators must only be operated with an appropriate controller, preferably with an AViTEQ-controller.

Do not operate the magnetic vibrators of the standard series MV... , as described in this operating manual, in areas with explosive gas atmospheres or in the presence of combustible dust. The magnetic vibrators aren't designed and approved for this case.

Please also observe the additional remarks about the intended use that are specified in chapter 1.3!

The vibration (conveyor) device (unit of magnetic vibrator and working unit) must be able to oscillate freely, without effecting neighboring components.

AViTEQ Vibrationstechnik GmbH does not take responsibility for injuries or damages which arise as a result of the use or the application of this product, which deviates from the data in the operating manual.

## For your Safety

You will find three different types of symbols in this operating manual which are intended to point out important information:



**DANGER!**

*The danger warning describes procedures or conditions which could lead to dangerous and even life-threatening consequences for the person installing or using the equipment.*



**ATTENTION!**

*You will find this information with procedures in which a danger of damage to equipment exists. This damage could also result in injury to personnel (e.g., from a fire or an explosion!).*



**NOTE**

*Notes provide information regarding individual tasks. Notes explain circumstances, clarify terminology or provide tips for simplifying processes or procedures.*

Even though the AViTEQ magnetic vibrators were developed with all safety measures for your protection, handling errors may occur. In the interest of your safety and that of your colleagues, please observe the following information:



**DANGER!**

*When the unit is connected to the mains, a lethal voltage is present inside the controller and the terminal box of the magnetic vibrator. Touching electrically live components can be lethal! Before switching on mains power, ensure that no live parts can be touched, the cover of the terminal box is closed and that all cable glands and insulations are undamaged.*



**DANGER!**

*Inadequate installation may cause the magnetic vibrator to fall down possibly causing injuries. Ensure that the magnetic vibrator is bolted on tight to the working unit and take appropriate steps to ensure that the vibration (conveyor) device cannot fall down! Remaining under the magnetic vibrator or the vibration (conveyor) device is **not** allowed!*



**DANGER!**

*Explosions can lead to perilous injuries and cause great damage to property! Magnetic vibrators in standard version without an ATEX-type examination certification **must not** be operated in areas with potentially explosive atmospheres consisting of a gas-, a vapour-, a mist- or a dust-air-mixture!.*



**ATTENTION!**

*It is totally prohibited that the current consumption of the magnetic vibrator exceeds the value of the nominal current specified on the type label, because this may lead to destroying the magnetic vibrator.*

---



**ATTENTION!**

*Unsuitable controller, operation without controller and/or operation with the incorrect mains voltage/frequency normally result in damage to the magnetic vibrator and is not allowed. Ensure that the connected loads are correct and compare them with the device type labels!*

---



**ATTENTION!**

*Changes of the air gap, the spring rate, the tightening torque of the spring mounting screws and/or operating the magnetic vibrator with an incorrect natural frequency (...observe characteristics curve data sheet) are not allowed, because this may lead to excessive heating of the drive, to short circuits between electromagnet windings, and eventually to the destruction of the drive.*

---



**ATTENTION!**

***Never** operate the magnetic vibrator without a counterweight (working weight), because this may lead to damaging the drive. The natural frequency can only be adjusted, if the magnetic vibrator has been fixed to a counterweight (working weight). Please observe this!*

---



**ATTENTION!**

*In the case of applications in the food industry a special lacquering may be required that is permitted for the food industry. Please observe this to avoid health risks of others.*

---

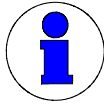

**NOTE**

---

*This operating manual refers only to the magnetic vibrators of the type: MV... for standard areas. For magnetic vibrators in special version for areas with the risk of explosion by a gas-, a vapour-, a mist- or a dust-air-mixture (type: eMV... (Ex)) there is a separate operating manual.*

---

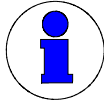

**NOTE**

---

*Depending on the construction of the working unit and the acoustic properties of the material transported, the sound pressure level of the operational vibration (conveyor) device may exceed 70 dB(A). It is the operator's responsibility to ensure adherence to the sound pressure level permitted by means of suitable noise protection measures!*

---



**NOTE**

---

*The item „nominal current“ that is used in this manual corresponds with the rated current and the limit current, as defined in the national standard VDE 0580.*

---

## **COPYRIGHT**

The AViTEQ magnetic vibrators of the series MV..., the VIBTRONIC® controller and this operating manual are protected by copyright. Any reengineering of the units will result in criminal prosecution. All rights of this operating manual are reserved, including reproduction via photo mechanical, print, data or any other possible medium, as well as in translation

Reproduction of this operating manual, complete or in part, requires the written consent of AViTEQ Vibrationstechnik GmbH. VIBTRONIC® is a registered and protected trademark of AViTEQ Vibrationstechnik GmbH.

This operating manual supports the intended use and appropriate deployment of AViTEQ magnetic vibrators. For this purpose, the operating manual describes details that are significant for the product's operation.

AViTEQ Vibrationstechnik GmbH is liable for textual errors in the operating manual only where intent and gross negligence are demonstrated. In such cases, liability is limited to the effects the textual errors have on the product specified in the contract and other associated products produced by AViTEQ Vibrationstechnik GmbH as well as required products produced by AViTEQ Vibrationstechnik GmbH which are used in technical combination. This aforementioned liability is limited to cases in which the value or functionality of the agreed upon characteristic of the product specified in the contract is vitiated or considerably diminished. This does not apply if liability for loss of life or limb or loss of health is mandatory.

The textual errors, the damages as well as the justification and resulting causality underlying the liability claim are to be proven by the purchaser. In particular, AViTEQ Vibrationstechnik GmbH is not liable for damages or consequential damages resulting from the incorrect use of the operating manual. This does not apply to faulty content of the operating manual. This does not apply if liability for loss of life or limb or loss of health is mandatory. We are always grateful for suggestions and criticism!

Unless otherwise stated, the relevant state of engineering is that at the time of the combined delivery of the product and the operating manual from AViTEQ Vibrationstechnik GmbH. The product is subject to technical changes without prior notice. Previous operating manuals no longer apply.

The *General Conditions of Delivery Domestic and Abroad* of AViTEQ Vibrationstechnik GmbH apply in their current version.

Do you have questions? Or problems with installation and commissioning?  
Give us a call! We'll be glad to help you!

AViTEQ Vibrationstechnik GmbH  
Im Gotthelf 16  
65795 Hattersheim-Eddersheim  
Germany

Phone ..... +49 / (0) 61 45 / 5 03 - 0  
Fax ..... +49 / (0) 61 45 / 5 03 - 200  
Fax ..... +49 / (0) 61 45 / 5 03 - 112 (Service-Hotline)  
E-Mail ..... [service@aviteq.de](mailto:service@aviteq.de)

Hattersheim-Eddersheim, 8<sup>th</sup> of October 2008

# CONTENT

<b>1</b>	<b>We are Partners</b>	<b>8</b>
1.1	About this Operating Manual .....	8
1.2	Product Liability and Warranty .....	9
1.3	Operative Range .....	11
1.4	Installation and Operating Personnel .....	12
1.5	Safety Instructions Regarding the Operating Location .....	12
1.6	Safety Precautions and Responsibilities of the Operator .....	12
1.7	EC-Directives .....	13
<b>2</b>	<b>Transport, Storage</b>	<b>14</b>
2.1	Extent of Delivery .....	14
2.2	Disposal .....	15
2.2.1	Packing Materials .....	15
2.2.2	Returning the Device .....	15
2.2.3	Materials Used in the Units .....	15
<b>3</b>	<b>Device Specification</b>	<b>16</b>
3.1	Construction and Principle of the Magnetic Vibrator .....	16
3.2	Tuning of the Oscillation System .....	17
3.2.1	Principles .....	17
3.2.2	Tuning Data .....	17
3.3	Sizes .....	20
3.3.1	Type Designation .....	20
3.3.2	Housing Sizes and Mounting Hole Dimensions .....	20
3.4	Sound Pressure Level .....	22
3.5	Separate Ventilation .....	22
<b>4</b>	<b>Installation</b>	<b>23</b>
4.1	Installation of the Working Unit .....	23
4.1.1	Working unit .....	23
4.1.2	Instructions for Working Units not Supplied by AViTEQ .....	23
4.2	Completing the Vibration Conveyor Device .....	24
4.2.1	Assembly Preparations .....	24
4.2.2	Installation .....	25
4.3	Mains Connection .....	28
4.3.1	Controllers .....	28
4.3.2	Connection Cable and Line Lengths .....	29
4.3.3	Connection Diagrams .....	29
4.3.4	Mains Connection .....	31
<b>5</b>	<b>Commissioning</b>	<b>32</b>
<b>6</b>	<b>Maintenance</b>	<b>34</b>
6.1	Regular Checks .....	34
6.2	Cleaning .....	35
6.3	Repairs .....	35
<b>7</b>	<b>Troubleshooting</b>	<b>36</b>
<b>8</b>	<b>Index</b>	<b>37</b>

# 1 We are Partners

## 1.1 About this Operating Manual

### For whom?

This operating manual is intended for

- Installation technicians installing and/or commissioning the magnetic vibrator and/or the vibration (conveyor) device.
- Engineers installing the controller, the electrical connection to the a.c. mains network and the connection to the magnetic vibrator.

All work on the electrical installation must be carried out by qualified personnel (electricians or persons trained in electrical engineering according to EN 60204-1).

### Additional publications

Supplements to this operating manual

- Connection diagram for the controller
- Operating manual for the controller
- Dimension sheet (drawing) of the magnetic vibrator
- Dimension sheet (drawing) of the working unit (...if delivered by AViTEQ)
- Characteristics curve data sheet for the magnetic vibrator
- List of spare parts for the magnetic vibrator

### Definitions

- *Magnetic vibrator:* electromagnetic-mechanical unit (vibration system) as it is shown on the front page
- *Working unit:* the conveyor unit (trough, tube or screen etc.) in multiple variations
- *Vibration (conveyor) device:* magnetic vibrator with the assembled working unit
- *Controller:* the separately shipped controller unit assigned to the magnetic vibrator for connecting to the a.c. mains network



### NOTE

*This operating manual refers only to the magnetic vibrators of the type: MV... for standard areas. For magnetic vibrators in special version for areas with the risk of explosion by a gas-, a vapour-, a mist- or a dust-air-mixture (type: eMV... (EX)) there is a separate operating manual.*

### Special symbols in this operating manual

Earlier in this manual, you should have learned how we indicate safety notices. If you have any questions about safe work practices regarding magnetic vibrators, you should give us a call!

For your convenience and orientation, we use the following special indicators in this operating manual:

- A round bullet indicates a listing of characteristics and conditions.
- ☝ The upward showing thumb tells you to check something, or read a summary.
- ☞ The pointing finger indicates steps that you have to carry out.

### Revision date

On the bottom on the right hand side page of this operating manual, the version number tells you the date when the page was last updated.



## 1.2 Product Liability and Warranty

The magnetic vibrators, type MV... correspond to the current State of Engineering and have been tested for each of its guaranteed functions prior to delivery. AViTEQ Vibrationstechnik GmbH carries out product and market research to aid further development and continuous improvement. Should malfunctions or failures occur despite these preventative measures, please contact our service department! We guarantee that appropriate measures for the repair of the defect will be taken immediately

### Conditions of Warranty

We guarantee that the product is free of defects within the scope of the technical product specifications published by AViTEQ Vibrationstechnik GmbH as well as technical specifications provided in this operating manual. No declarations of other product features or claims regarding additional characteristics are provided. AViTEQ Vibrationstechnik GmbH is not liable for the economic efficiency of the product or proper functionality when used for applications other than the purpose defined for the product as specified on the first, left-hand inner page in the front of this operating manual.

### Warranty Exclusions

Customers and third parties must not undertake work inside or otherwise interfere with the product, except the works that are described in this operating manual. Otherwise, liability for devices, persons and other consequential damages of any type to the product specified in the contract and other legal assets is precluded, provided AViTEQ Vibrationstechnik GmbH is not co-responsible. Entering into or interfering with the equipment also renders any warranty null and void.

AViTEQ Vibrationstechnik GmbH does not accept liability beyond the warranty entitlements stated in our terms of business on which the contract is based. This applies in particular to claims arising from loss of profit or other damage to purchaser/customer assets. This liability limitation does not apply unless the damage was intentional or caused through gross negligence and unless liability for loss of life or limb or loss of health is mandatory. This also does not apply when the purchaser/customer makes a claim for damages based on an incorrect claim of a characteristic or an agreed-upon characteristic. In the event of culpable violation of principle contractual obligations, AViTEQ Vibrationstechnik GmbH is also liable for criminal intent and gross negligence on the part of non-managing employees and for mild negligence. In the latter case, this is limited to the contract-typical, judicious, predicable damages.

Warranty is excluded in particular when the units are used in environments, for purposes, or connected to power supplies or to control systems that are not suitable for the magnetic vibrators or that do not represent the common state of technology. In particular, no warranty is provided for damages caused by unsuitable or incorrect use, incorrect mounting or commissioning by the purchaser/customer or third parties, natural wear, faulty or careless handling or unsuitable operating materials. The same applies for replacement parts, chemical, electrochemical or electrical influences provided they cannot be attributed to AViTEQ Vibrationstechnik GmbH and its employees. Claims made for damages to objects other than that which is specified in the contract, so-called deficiency losses, are limited. In this case, AViTEQ Vibrationstechnik GmbH is liable, regardless of the legal basis, only in the cases of

The "General Conditions of Delivery Domestic and Abroad" of AViTEQ Vibrationstechnik GmbH apply in their current version.

---

intent, gross negligence on the part of the owner/of its management or managing employee in the event of culpable loss of life or limb or health, in the event of deficiencies which are fraudulently concealed or the absence of which AViTEQ guaranteed, in the event of deficiencies of the delivered object, provided liability is provided in accordance with the product liability law for injury to persons and damages to materials or other special legal requirements.

Likewise, no warranty is provided for damages to conveyance and automation systems which are the result of a malfunction of the product or a textual error in the operating manual. The warranty excludes damages which are the result of accessories not supplied or certified by AViTEQ Vibrationstechnik GmbH. AViTEQ Vibrationstechnik GmbH is not responsible for the violation of patent rights and other titles of third parties outside of the Federal Republic of Germany.

We would like to point out that we are not liable for damage to the product subject to the contract, or for consequential damage to other property, if the damage is caused by non-observation of safety regulations and/or warning notices.

When entering the contract, the purchaser/customer is obliged to point out explicitly if the product is intended for private use and will be used by the purchaser/customer predominantly for this purpose.

The magnetic vibrators described in this operating manual must not be operated without consultation and corresponding release by AViTEQ Vibrationstechnik GmbH in the United States of America and other countries where US American laws are applicable.

## 1.3 Operative Range

AViTEQ magnetic vibrators in standard version are designed and intended as drives for vibration (conveyor) devices for removing, conveying, distributing, condensing, mixing up, dosing and/or screening of bulk materials **outside of** areas with the risk of explosion by a gas-, a vapour-, a mist- or a dust-air-mixture.

Magnetic vibrators are used as components of conveyor and automation plants. Sample applications are...

- general industry use for the transport and screening of, e.g. shavings, plastic- or paint-powder, chemicals, etc.
- food industry for the transport and screening of, e.g. baking ingredients (flour, sugar, etc.), spices, biscuits, cereals, etc.



### NOTE

*We carry out experiments for products whose transportation properties are unknown. Give us a call!*

Never use in the following cases:

- *Do not use* with mains voltages and mains frequencies that, according to the information on the type label, are not adapted for the magnetic vibrator.
- *Do not use* in areas with ambient temperatures below **- 20°C** and above **+ 40°C**, or in tropical climate! The units are designed for operation in moderate climate environments. Special versions for non-moderate climate environments or for lower or higher ambient temperatures might be possible on request.
- *Do not use* at elevations above 1,000 m above sea level without first consulting AViTEQ Vibrationstechnik GmbH.
- *Do not use* in the food industry with standard lacquering, if a special lacquering is required that is permitted for the food industry. On request the drives can be carried out with a special lacquering that is suitable for the food industry.
- *Do not use*, if potentially explosive atmospheres are consisting of a gas-, a vapour-, a mist- or a dust-air-mixture.

### Connection with the controller

The magnetic vibrators in standard version must only be operated with an appropriate controller, preferably with an AViTEQ-controller. A suitable controller exists for every magnetic vibrator.

Other control and connection options are not included.

## 1.4 Installation and Operating Personnel

Prior to installation and/or commissioning, you must be familiar with all details and connection configurations of the magnetic vibrator.

Persons involved with installation, commissioning, assembly, disassembly, adjustment or maintenance must have read and understood this operating manual in its entirety; in particular the safety notes. If you have any questions, we would be glad to help you!

All work on the electrical installation must be carried out by qualified personnel (electricians or persons trained in electrical engineering according to EN 60204-1).



**NOTE**

*The magnetic vibrators for standard areas are only allowed to be repaired by AVITEQ Vibrationstechnik GmbH or by special staff that has been trained and authorised by AVITEQ. AVITEQ Vibrationstechnik GmbH is not liable for damage to property and/or person in the case of neglect!*

## 1.5 Safety Instructions Regarding the Operating Location

- Supports and buildings must be designed to withstand the static load and dynamic stresses of the magnetic vibrator(s), the vibration (conveyor) device and the bulk material.
- The magnetic vibrator with the vibration (conveyor) device has to be located in such a way that an adequate safety distance of 120 mm is present on all sides. Working stroke and safety distance must be kept free.
- For adjustment, inspection, and maintenance purposes, the magnetic vibrator must be accessible at all times.

## 1.6 Safety Precautions and Responsibilities of the Operator

This operating manual is part of the magnetic vibrator and must be available to qualified personnel at any time. The following has to be observed:

- Qualified personnel must have appropriate tools and test equipment at their disposal.
- Qualified personnel must be trained in safe work practices and must be familiar with the safety notes.
- The operator must obtain a local operating permit and observe any conditions relating to it.
- EC regulations in their current version are to be observed. This applies in particular to EN 60 204-1 regarding machine safety and electrical equipment of machines.
- The operator may only use the magnetic vibrator if it is in perfect condition and in a proper state.

Please observe the following:

- All works on the magnetic vibrator require that you observe the safety notes as they are shown in this operating manual.
- Avoid any work practice that compromises safety in relation to the magnetic vibrator. **You must not disable any safety mechanisms!**
- Any changes relating to the magnetic vibrator that could compromise safety must be reported to the operator immediately.

## **1.7 EC-Directives**

The magnetic vibrator is not a standalone machine in the sense of the EC Machinery Directive 98/37/EC, and only intended for use together with another machine. Operation is prohibited until it has been established that the machine that is handed to the operator complies with the regulations of the EC directive. The magnetic vibrator was built in accordance with these regulations. The associated Manufacturer's Declaration can be found on page 39.

Further the magnetic vibrator complies with the regulations of the EC Directive 2006/95/EC relating to electrical equipment designed for use within certain voltage limits. The associated Declaration of Conformity can be found on page 38.

## 2 Transport, Storage

The magnetic vibrators and possible equipment are delivered by AVITEQ in appropriate packaging to ensure that they reach their destination undamaged



### NOTE

*If the packing is visibly damaged in a way that indicates damage to the contents, contact the forwarding agent! In further proceedings, take notice of the General Conditions of Business of the forwarding agent in order not to risk your claim for damages by improperly filled out forms!*

- ☞ Storage: Unless special agreements concerning packing and storage have been made, the units, either packed or unpacked, must be stored and transported under „normal“ conditions. This means in enclosed rooms with temperatures between  $-25^{\circ}\text{C}$  and  $+50^{\circ}\text{C}$ , relative humidity not exceed 80%.

When transporting the unpacked magnetic vibrator or the vibration (conveyor) device, it is easy to avoid damage by observing the following points:

- ☞ For transporting the magnetic vibrator use appropriate hoisting devices and lift the unit by the suspension points.
- ☞ Avoid contact with pointed or sharp (metallic) objects that could damage the lacquer coating!
- ☞ Always place the unit onto a secure support base and position, such that the unit cannot tip or fall down!

The dimensions, the weight and the position of the centre of gravity can be found on the separate drawing that exists for every magnetic vibrator.



### ATTENTION!

*Transporting and storing the units under inappropriate conditions may cause permanent damage. Such damage may not be detectable from the outside. AVITEQ does not cover this case in its warranty and is not liable for any consequential damage.*

### 2.1 Extent of Delivery

After unpacking, check the delivery note and accompanying documentation to ensure that all the parts have been supplied and are undamaged.

Compare the information on the type label of the magnetic vibrator, the working unit and the controller with the delivery note and order documentation!



### ATTENTION!

*Destruction of magnetic vibrator and controller possible, if the units don't match! Only operate units that belong together!*

In the case of applications in the food industry, please check, if the magnetic vibrator was delivered with a special lacquering.

## 2.2 Disposal

### 2.2.1 Packing Materials

The following materials are used by AViTEQ for delivering the magnetic vibrators, depending on the type of transport:

- Polyethylene foil (PE) for device protection
- Corrugated cardboard for outer and inner packing
- Wooden cases for outer packing
- Paper shavings as filler material
- Styrofoam (Flo-Pack) as filler and cushioning material

All packing materials should be disposed of in accordance with local regulations of the delivery destination.



Cardboard containers and paper packing tapes can be recycled within the RESY Disposal and Re-utilisation System. Where used, packaging foil, packing tapes, and foam foils are made from polyethylene (PE), the CFC-free cushions are usually made from polystyrene foam (PS). These packing materials consist of pure hydrocarbons and can thus be recycled.

In special cases, we use steel packing bands and wooden cases free of chemical treatment..

### 2.2.2 Returning the Device

AViTEQ Vibrationstechnik GmbH will accept without charge magnetic vibrators, type: MV... that have been delivered in 1990 or later when delivered shipping paid to AViTEQ Vibrationstechnik GmbH, 65795 Hattersheim-Eddersheim, Germany.

AViTEQ guarantees for a professional disposal. Therefore the magnetic vibrators have to be free of product arrears and pollutants. Otherwise AViTEQ is justified to refuse the acceptance of the drive.

### 2.2.3 Materials Used in the Units

In case of disposal by the customer, and when exchanging components, the current local waste and disposal regulations apply and should be observed. We accept no responsibility for improperly disposed parts and components!

- The regulations for the disposal of electronic parts and components apply to the disposal of the controller.
- The power semiconductors used (triacs and diode modules) do not contain beryllium.



#### NOTE

---

*More detailed information on the materials used is available from us on request. In case of doubt, please do make use of our recycling service!*

---

## 3 Device Specification

### 3.1 Construction and Principle of the Magnetic Vibrator

AViTEQ magnetic vibrators are used as drives for vibration (conveyor) devices. A vibration (conveyor) device consists of at least the following components:

- Magnetic vibrator
- Working unit (trough, tube, screen etc.) with support elements (e.g. rubber pads)
- Controller

Further supply devices may be part of the unit.

The construction concept of the magnetic vibrator including the vibration (conveyor) device is shown in the figure below.

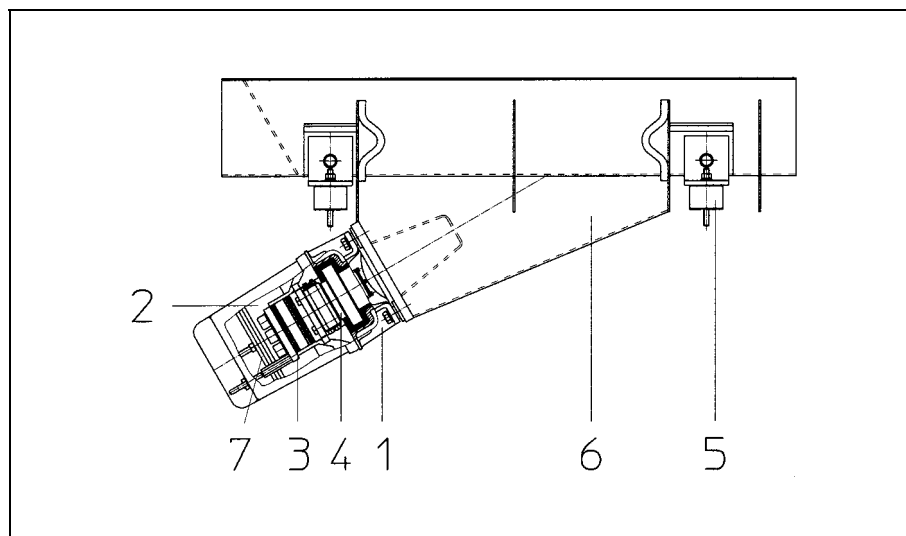

Image 3-1 Construction of the magnetic vibrator and the vibration (conveyor) device

Together with the working unit the magnetic vibrator forms a two-mass oscillation system and is, among other things, made up of the main components: working side (1), inoperative side (2) with the auxiliary weights (7), leaf springs (3) and electromagnet (4).

The electromagnet (4) generates a straight-path upwardly oscillation motion. The working unit (6) that is mounted to the working side (1), transmits the oscillation motion to the transported material. Together the working side with the electromagnet (4) and the working unit form one mass unit within the oscillation system. The inoperative side (2) with the auxiliary weights (7) represents the counter-mass. Both masses are connected by leaf springs (3). Support elements (e.g. rubber pads) (5) support the oscillation system to its environment.

Each voltage cycle exerts a pulling force on the electromagnet (4). Depending on the type of the magnetic vibrator the unit oscillates with 1,500 or 3,000 oscillations per minute at a 50 Hz-mains. By changing the voltage from the controller, the working stroke and hence the throughput may be adjusted during operation from close to 0 up to 100 %.



## 3.2 Tuning of the Oscillation System

### 3.2.1 Principles

Vibration drives are spring-mass oscillation systems that exploit the resonance of the oscillation system. If the system is stimulated, it continues to oscillate with its natural frequency, with a decaying amplitude depending on its attenuation properties.

If a sinusoidal force acts on this system with a frequency different from the natural frequency (vibration frequency or drive frequency), the entire system will no longer oscillate at its natural frequency (resonance frequency), but will follow the rhythm of the force exerted on it (forced oscillation).

The closer the natural and the vibration frequency are, the larger the working stroke. However, for electromagnetic vibration drives, operation in the immediate vicinity of the natural frequency is critical, because retroactivities of the transported material like attenuation and coupling effects may have negative effects. For a stable operation of the oscillation system, a well-defined distance from the natural frequency is required. In this case, the natural frequency may be lower or higher than the vibration frequency.

AViTEQ magnetic vibrators, as described in this manual, always work in sub-critical operation. The natural frequency of the oscillation system is greater than the vibration frequency.

### 3.2.2 Tuning Data

For every magnetic vibrator there is a related characteristics curve data sheet that contains all relevant information for tuning the magnetic vibrator. Figure 3-2 on the following page shows the characteristics curve data sheet for the MVE 25-4 as an example.



**ATTENTION!**

*Changes of the air gap, the spring rate, the tightening torque of the spring mounting screws and/or operating the magnetic vibrator with an incorrect natural frequency (...observe characteristics curve data sheet) are not allowed, because this may lead to excessive heating of the drive, to short circuits between electromagnet windings, and eventually to the destruction of the drive.*



**NOTE**

*For measuring the natural frequency you do need an adequate measuring device. This can be either a frequency meter or an electronical measuring device with an oscillation sensor that is able to analyse the natural frequency. Measuring the natural frequency is always carried out without load (without bulk material), because the damping and coupling of the bulk material doesn't allow an exact measuring result. The natural frequency that is shown in the characteristics curve data sheet is valid only for vibration (conveyor) devices **without load!***

The shown conveying velocities apply for earth-moistly sand, an angle of impact of 30°, a tilt angle of 0° and a height of the layer of 200 mm. Depending on the material to be conveyed, the moisture, the conveying willingness of the material, the height of the layer, etc., differing conveying velocities normally will be seen in practice. (Source: VIB 03-764b EN - 29.11.2005)

**Horizontal conveying velocity (cm/s)**

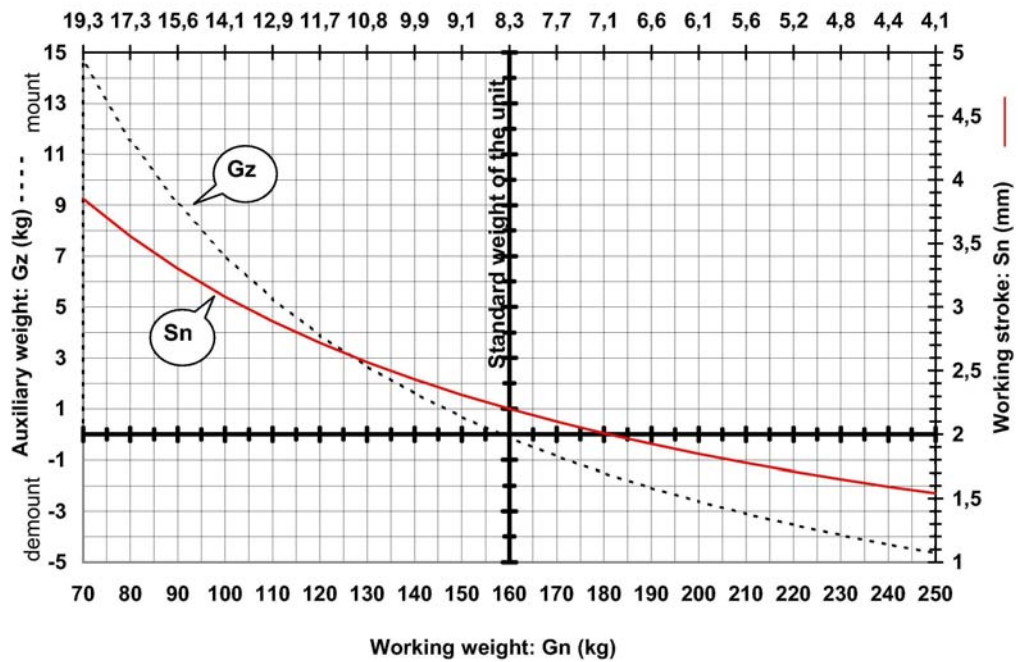

Copying of this document, and giving it to others and the use or communication of the contents thereof, are forbidden without express authority. Offenders are liable to the payment of damages. All rights are reserved in the event of the grant of a patent or registration of a utility model or design.

Vibrator		Controller type:					
$U_E$	$I_G$	SC(E)-EN...		SA(E)-...		SR(E)-...	
		$U_{VN}$	$U_{VA}$	$U_{VN}$	$U_{VA}$	$U_{VN}$	$U_{VA}$
230 V	14 A	139 V	$\geq 145$ V	139 V	$\geq 145$ V	139 V	$\geq 145$ V
400 V	8,0 A	262 V	$\geq 274$ V	262 V	$\geq 274$ V	258 V	$\geq 270$ V
500 V	6,1 A	334 V	$\geq 346$ V	334 V	$\geq 346$ V	330 V	$\geq 342$ V

Natural frequency :  $27,5 \pm 0,5$  Hz  
Air gap (trough) : 6,8..7,1 mm

Image 3-2 Characteristics curve data sheet

The allowed working weight range, the associated working stroke and the necessary auxiliary weight „Gz“ - depending on the working weight „Gn“ - are shown on the characteristics curve data sheet.

Depending on the value of the working weight „Gn“ auxiliary weight has to be added or taken away for adjusting the correct natural frequency.



**ATTENTION!**

---

*The natural frequency that is shown on the related characteristics curve data sheet **must** be compellingly kept. Check this before commissioning.*

*If the natural frequency lies above the allowed value, the active power consumption of the magnetic vibrator will increase which leads to an unallowable heating of the drive. Damage to the magnetic vibrator is possible! AViTEQ Vibrationstechnik GmbH is not liable for damage to property or person in the case of neglect!*

*If the natural frequency lies below the allowed value, the risk of operating the magnetic vibrator in collision mode increases. Further the active power consumption of the magnetic vibrator might increase which leads to an unallowable heating of the drive. Damage to the magnetic vibrator is possible! AViTEQ Vibrationstechnik GmbH is not liable for damage to property and/or person in the case of neglect!*

---



**NOTE**

---

*Depending on the type of controller and the particular mains voltage ( $U_E$ ), the vibrator nominal voltage ( $U_{VN}$ ) and the vibrator collision voltage ( $U_{VA}$ ) are shown on the characteristics curve data sheet. The values for the vibrator nominal voltage and the vibrator collision voltage apply only to the associated mains voltage (e.g. 400 V) that is shown in the table.*

*Instead of a constant value for the mains voltage you will find a mains voltage range on the type label of the AViTEQ-controllers and also on the type label of certain AViTEQ magnetic vibrators. If the mains voltage that you do measure in practice differs from the mains voltage that is shown on the characteristics curve data sheet, you have to check the difference between the vibrator nominal voltage and the vibrator collision voltage and, if necessary correct the setting at the controller.*

*Operating the magnetic vibrator with a mains voltage that differs from the mains voltage value or that is outside the mains voltage range that is shown on the type label of the magnetic vibrator including an allowed tolerance of  $\pm 10\%$  is forbidden. In the case of neglect AViTEQ is not liable for the consequences!*

---



**NOTE**

---

*For every magnetic vibrator there is an appropriate characteristics curve data sheet that is needed for a correct tuning of the magnetic vibrator. Before mounting the magnetic vibrator, please check if the appropriate characteristics curve data sheet is present and observe the shown data!*

---

### 3.3 Sizes

#### 3.3.1 Type Designation

AViTEQ-magnetic vibrators are available in different sizes and executions. The type designation contains the following information:

##### MVES50-1P-TE

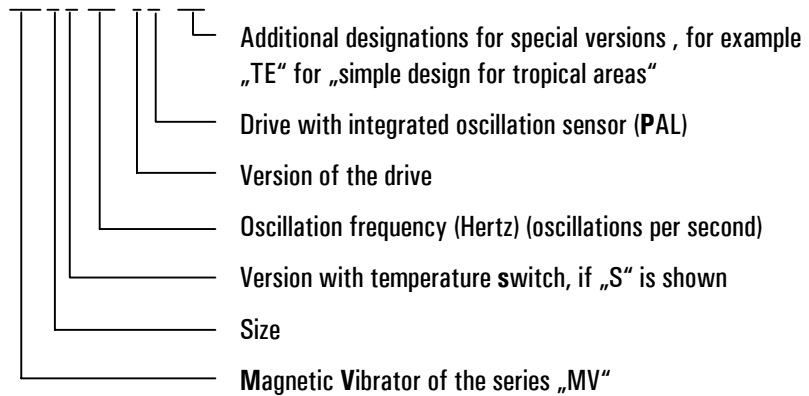

#### NOTE

All magnetic vibrators with an integrated oscillation sensor (PAL) and/or a temperature switch are completed with a 5-core connexion cable by AViTEQ. There are some exceptions from the type designation that is shown above. The MVF 30-4, the MVG 33-1, and the MVH 33-1 do have an integrated temperature switch without showing the code letter „S“ in their type designation. Further the MVG 33-1 and the MVH 33-1 do have an integrated oscillation sensor (PAL) without showing the code letter „P“ in their type designation.

#### 3.3.2 Housing sizes and Mounting Hole Dimensions

The dimensions are contained in the product specifications for AViTEQ magnetic vibrators (separate drawing) or in the brochure, which are available separately.

On the following page you can find the dimensions of the hole pattern for every magnetic vibrator. Depending on the size, the drive is fixed with 2 or 4 screws.

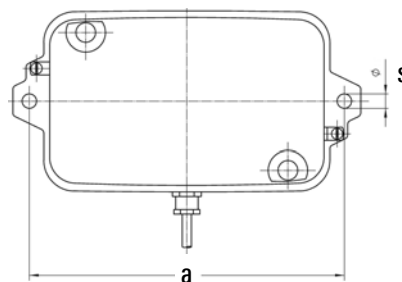

Size	a [mm]	b [mm]	s [mm]	Number of mounting holes (Screw size)
MV1...	200	-	9,0	2 (M8)
MV6...	240	-	11,0	2 (M10)

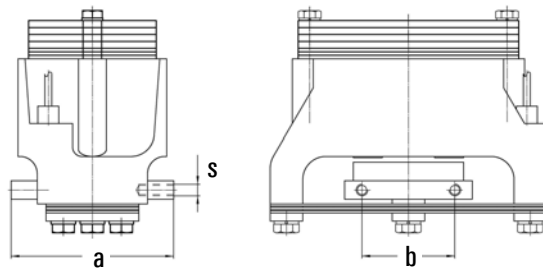

Size	a [mm]	b [mm]	s [mm]	Number of mounting holes (Screw size)
MVB...	140	80	M10	4 (M10)

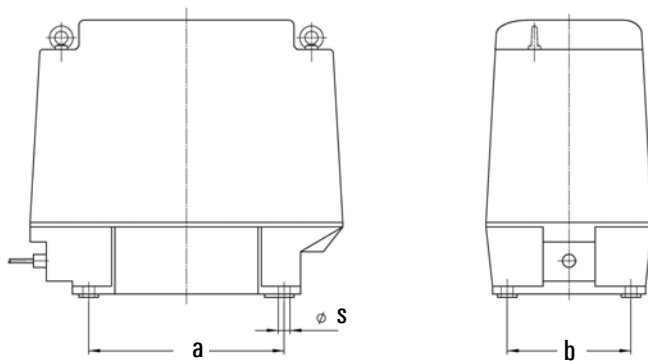

Size	a [mm]	b [mm]	s [mm]	Number of mounting holes (Screw size)
MV12.. MVC.. MVD...	210	125	11,5	4 (M10)
MVE.. MVES...	300	190	18,0	4 (M16)
MVF30.. MVFS...	350	240	22,0	4 (M20)
MVG.. MVGS...	500	280	27,0	4 (M24)
MVH...	420	420	33,0	4 (M30)

---

### 3.4 Sound Pressure Level

The magnetic vibrator generates a sound pressure level of less than 70 dB(A) without considering the working unit or the transported material. Depending on the construction of the working unit and the acoustic properties of the material transported, the sound pressure level of the operational vibration (conveyor) device may exceed 70 dB(A). It is the operator's responsibility to ensure adherence to the sound pressure level permitted by means of suitable noise protection measures

### 3.5 Separate Ventilation

Cooling with fresh air is required, if magnetic vibrators are operated in areas with an ambient temperature that exceeds +40°C. For this AViTEQ delivers modified magnetic vibrators in a special version with a separate ventilation.



**NOTE**

---

*Magnetic vibrators in special version with a separate ventilation are marked with the code letters "FB" in the type designation. These drives have an inlet-nozzle for the air supply. The allowed maximum overpressure is 15 up to 20 hPA (mbar), the inlet-temperature of the fresh air must not exceed +40°C.*

---

Depending on the ambient temperature and the magnetic vibrator type some 2 up to 75 m<sup>3</sup>/h fresh air are need for the ventilation. If the vibration (conveyor) device has been delivered by AViTEQ, normally information about the amount of fresh air that is needed are given in the appropriate dimension sheet (drawing). The fresh air cools down the electromagnet and escapes through holes that are located in the protective hood or the working side.

## 4 Installation

### 4.1 Installation of the Working Unit

#### 4.1.1 Working Unit

Essential part of the vibration (conveyor) device is the working unit. The working unit can be part of the AViTEQ delivery but also been made by the customer himself.



#### NOTE

---

*If the working unit has been designed and manufactured by AViTEQ, the associated working weight „Gn“ is shown on the type label of the working unit. To protect the magnetic vibrator from damage during transport, AViTEQ delivers the magnetic vibrator and the working unit unmounted. While mounting the magnetic vibrator and the associated working unit, make sure that the correct combination of magnetic vibrator and working unit have been chosen. Therefore check the information that are given in the shipping documents (dimension sheet) and on the type label of the working unit.*

---

#### 4.1.2 Instructions for Working Units not Supplied by AViTEQ

If you want to build your own working unit (trough, tube, screen, etc.), please observe the following advices:

- ☞ The working unit has to be stiff to avoid bending. The sheet metal fields have to be designed in a way that no sheet metal field resonance perform.
- ☞ The maximum allowable tolerance for the evenness for the bearing surface for the fixing of the magnetic vibrator at the saddle (working unit) is  $\pm 0,2$  mm. Breaking of the feet and therewith the destruction of the drive are possible in the case of neglect. A falling down of the drive may be the result.
- ☞ Operating noise: the magnetic vibrator generates a sound pressure level of less than 70 dB(A) without considering the working unit or the transported material.

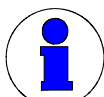

#### NOTE

---

*Depending on the construction of the working unit and the acoustic properties of the material transported, the sound pressure level of the operational vibration (conveyor) device may exceed 70 dB(A). It is the operator's responsibility to ensure adherence to the sound pressure level permitted by means of suitable noise protection measures!*

---

- ☞ On customers request AViTEQ carries out a so-called pre-tuning of the magnetic vibrator, if the value of the working weight (without the weight of the load) is known when ordering the magnetic vibrator!

## 4.2 Completing the Vibration Conveyor Device

Normally first the magnetic vibrator is fixed to the working unit before the vibration (conveyor) device (unit of magnetic vibrator and working unit) is built into the installation.



*Before first commissioning, make sure that the vibration (conveyor) device can oscillate without colliding with other parts and that all screws are tightened correctly.*

The following description characterises the normal sequence for completing the vibration (conveyor) device by fixing the magnetic vibrator to the working unit before the vibration (conveyor) device (unit of magnetic vibrator and working unit) is built into the installation and tuned.

### 4.2.1 Assembly preparations

- ☞ Do magnetic vibrator and working unit match? Therefore check the data on the type labels of the magnetic vibrator and the working unit.
- ☞ The magnetic vibrator can be mounted in every possible position. Check the bearing surfaces for fixing of the magnetic vibrator at the magnetic vibrator and the working unit. The bearing surfaces must be even and free of burrs, of grease and of lacquer.



*The maximum allowable tolerance for the evenness for the bearing surface for the fixing of the magnetic vibrator at the saddle (working unit) is  $\pm 0,2$  mm, the allowed surface roughness 50 micrometre. Breaking of the feet and therewith the destruction of the drive are possible in the case of neglect. A falling down of the drive may be the result and may lead to an injury to personnel.*

- ☞ Choose the correct screws for fixing the magnetic vibrator. The particular screw length for threaded holes and the screw size are indicated in the following table. The recommended length of engagement is valid for threaded holes and working units (saddle) made of steel. Choose screws with a bolt quality of at least 8.8 and clean the screw thread from oil deposits!

Magnetic vibrator type	Number of screws	Screw size	Length of engagement (recommended)	Screw length (maximum)
MV 1 ...	2	M 8	8 mm	-
MV 6...	2	M10	10 mm	-
MV12...	4	M10	10 mm	30 mm
MV B...	4	M10	15 mm	-
MV C... MV D...	4	M10	10 mm	45 mm
MV E... MV ES...	4	M16	20 mm	50 mm
MV F30-4 MV FS...	4	M20	25 mm	70 mm
MV G33-1 MV G50-11	4	M24	35 mm	130 mm
MV G50-2 MV G60-2	4	M24	35 mm	80 mm
MV GS... MV GS...	4	M24	35 mm	130 mm
MV H... MV H...	4	M30	45 mm	110 mm

Table 4-1 Fixing screws



- ☞ In the case of threaded holes we recommend to use Loctite 275 up to a screw size of M12 and Loctite 245 for screw sizes of M16 or larger for securing the screws.



**NOTE**

*If the working unit and the magnetic vibrator were delivered by AViTEQ, the adjustment of the natural frequency has already been carried out by AViTEQ. Normally the magnetic vibrator and the working unit are delivered unmounted. On the type label of the working unit you will find amongst others the value of the working weight and the serial number and type of the associated magnetic vibrator. While mounting the magnetic vibrator with the working unit make sure that both match according to the information on the type labels and check the natural frequency before commissioning. In the case of neglect damage to the magnetic vibrator and an unallowable heating of the drive are possible. AViTEQ Vibrationstechnik GmbH is not liable for damage to property and/or person in the case of neglect!*

Loctite is a trademark of the company Henkel KGaA.

### 4.2.2 Installation



**DANGER!**

*Danger of crushing! Avoid unintended swinging of the magnetic vibrator on the hoist during the transport. Further prevent the magnetic vibrator from falling down by securing it appropriately!*

- ☞ Screw the magnetic vibrator onto the working unit. Tighten the fixing screws with the torque indicated in the following table.

Screw size	Screw tightening torques (Bolt quality 8.8)
M 8	25 Nm
M10	49 Nm
M16	210 Nm
M20	400 Nm
M24	730 Nm
M30	1450 Nm

Table 4-2  
Screw tightening torques



**NOTE**

*In the case of through holes, each nut must be secured by a locknut. If it is not possible to use such a locknut, the nut must be secured using Loctite, just as in the case of threaded holes.*

*Alternative: Depending on the vibration (conveyor) device it is also possible to use stud bolts and locknuts.*

- ☞ Now integrate the vibration (conveyor) device into the installation. Use suitable support elements. AViTEQ Vibrationstechnik GmbH normally uses rubber pads for an oscillation frequency of 50 Hz and rubber hollow pads for an oscillation frequency of 25 Hz.



**DANGER!**

---

*Before first commissioning, make sure that the vibration (conveyor) device can oscillate without colliding with other parts and that all screws including the screws of the support elements are tightened correctly.*

*Caused by a relative movement between the support elements and the base frame and/or the working unit due to unfixed support elements destruction of the support elements is possible. Make sure that this can't happen!*

---

- ☞ After the magnetic vibrator has been fixed to the working unit and the vibration (conveyor) device has been integrated into the installation and can oscillate freely, the natural frequency must be checked and if necessary set to the correct value. The value of the associated natural frequency with the allowed tolerance is shown on the characteristics curve data sheet. For tuning the magnetic vibrator first remove the protective hood, if necessary.
- 



**ATTENTION!**

---

***Collision mode due to a too low natural frequency!** Therefore deviations from the allowed natural frequency are **not allowed**, because this may lead to excessive heating of the drive, to short circuits between electromagnet windings, and eventually to the destruction of the drive.*

---



**ATTENTION!**

---

***Destruction of the magnetic vibrator caused by an improperly high natural frequency possible!** Therefore deviations from the allowed natural frequency are **not allowed**, because this may lead to excessive heating of the drive, to short circuits between electromagnet windings, and eventually to the destruction of the drive.*

---

- ☞ Detect the value of the auxiliary weight that has to be added or taken away on the basis of the characteristics curve data sheet.
- 



**NOTE**

---

*On the type label of the magnetic vibrator you can find the weight specification „Gz0=...kg“. This information says, how many auxiliary weight has been added during production to tune the magnetic vibrator at its standard weight according to the characteristics curve data sheet. Normally the auxiliary weights are unpainted.*

*If you replace the magnetic vibrator, maybe because the old drive is damaged, you can proceed as follows for presetting the natural frequency:*

- 1. Remove all auxiliary weights of the old magnetic vibrator and identify the total weight by weighing the weights.*
- 2. Compare the total weight of the auxiliary weights of the old magnetic vibrator with the weight specification „Gz0“ on the type label of this old magnetic vibrator. If the total weight is less than the weight specification “Gz0” remove the difference in weight at the new magnetic vibrator. If the total weight is greater than the weight specification “Gz0” add the difference in weight at the new magnetic vibrator.*

*If the weight specification „Gz0=...kg“ is missing on the type label, you can contact AVITEQ to find out about the value of the weight. Therefore you have to inform us about the magnetic vibrator type and the serial number of the drive.*

---

- ☞ Loosen the fixing nuts of the auxiliary weight(s) and alter the weight. Then tighten the fixing nuts again.
- ☞ Then detect the natural frequency by observing the following notes:



**NOTE**

---

*For measuring the natural frequency you do need an adequate measuring device. This can be either a frequency meter or an electronical measuring device with an oscillation sensor that is able to analyse the natural frequency. AViTEQ offers appropriate measuring devices that normally can be borrowed by paying a fee.*

---



**NOTE**

---

*Measuring the natural frequency is always carried out without load (without bulk material), because the damping and coupling of the bulk material doesn't allow an exact measuring result. The natural frequency that is shown in the characteristics curve data sheet is valid only for vibration (conveyor) devices **without load!***

---



**NOTE**

---

*For adjusting the natural frequency by altering the auxiliary weight the protective hood of the magnetic vibrator has to be demounted. Please observe that the weight of the protective hood has an influence on the natural frequency too. For a correct measurement of the natural frequency after altering the auxiliary weight the protective hood has to be mounted again. Alternatively a compensation weight that complies with the weight of the protective hood, can be added to the working weight so that you don't need to mount the protective hood for every measurement. This compensation weight has to be removed again, after the natural frequency has been adjusted.*

---



**NOTE**

---

*The auxiliary weight that is shown on the characteristics curve data sheet and that depends on the working weight has tolerances. Therefore it is important and required to check the natural frequency. AViTEQ Vibrationstechnik GmbH is not liable for damage to property or person in the case of neglect!*

---

- ☞ After the tuning of the magnetic vibrator has been carried out with success, do mount the protective hood again.

## 4.3 Mains Connection

### 4.3.1 Controllers



---

*Magnetic vibrators must only be operated with the appropriate controller. In the case of neglect AViTEQ is not liable for the consequences!*

*Magnetic vibrators in normal version without an ATEX-type examination certification **must not** be operated in areas with potentially explosive atmospheres consisting of a gas-, a vapour-, a mist- or a dust-air-mixture!*

---

The following AViTEQ controllers with different characteristics are applicable and can be designated:

- **SRA(E)...**, series with voltage regulation for nominal currents up to 6,0 A with soft start. Mains voltage fluctuations are compensated and are almost without an effect on the conveyor capability. Optional the controller can be delivered with a level scanning system / part overflow controller. Controllers with a level scanning system / part overflow controller are specially designed for linking several vibration conveyor devices.



---

*For using the level scanning system or the part overflow controller a appropriate sensor is needed. Unless the sensor isn't part of the AViTEQ supply, AViTEQ isn't responsible for the sensor selected and therefore further isn't liable for damages that result out of incorrect selection and an incorrect case of operation of a sensor that isn't permitted for the case of operation.*

---

- **SC(E) ...**, series with voltage regulation for nominal currents up to 15,0 A with soft start. Mains voltage fluctuations are compensated and are almost without an effect on the conveyor capability.
- **SA(E) ...**, series with voltage regulation for nominal currents up to 43 A with soft start. Mains voltage fluctuations are compensated and are almost without an effect on the conveyor capability.
- **SD(E) ...**, series with voltage regulation for nominal currents up to 100 A with soft start and digital controller unit. Mains voltage fluctuations are compensated and are almost without an effect on the conveyor capability.

The controllers can optionally be delivered in the following versions:

- **Cabinet unit** (IP54), controller in a closed housing. Depending on the type of controller, the terminals are designed pluggable and a potentiometer and a switch (On/Off) are integrated on the front plate. Delivered with an appropriate operating manual and possible accessories (e.g. plug etc.).
- **Panel mounting unit** (IP00 or IP20), controller for installation in switching cabinets or control cases. Depending on the type, the fixing of the controller results from mounting onto a top hat rail or bolting together with a subplate. Delivered with an appropriate potentiometer (delivered loose) and operating manual.

### 4.3.2 Connection Cable and Line Lengths

<b>AVITEQ</b>		Vibrationstechnik GmbH www.aviteq.de	
Type	Serial no.	Year	
V	A	Hz	/min
Operate only with appropriate connector set		GzQ+	kg
Magnetic Vibrator	Magnehvibrator	Vibrateur magnetique	
VDE 0580		Made in Germany	



Choose the connexion cables according to the nominal current (observe information on the type label) and the cable length. The voltage drop should not exceed 5%.

When you install the cable between the magnetic vibrator and the controller, please observe the following:

- ☞ The cable length must not exceed **300 m**.
- ☞ Only use a cable whose insulation suits the special environmental conditions. For pharmaceutical and food processing applications, you might have to choose sterilisable insulations, if required.
- ☞ In the proximity of the magnetic vibrator, run the cable in such a way that contact with vibrating parts is impossible.



*Short circuits and electric shock may result if insulation is damaged by rubbing! Connecting cables must **never** come in contact with vibrating parts – otherwise, the insulation may get damaged. Run the cables in a way that excludes this danger!*

- ☞ Avoid cable loops! Shorten cables if required.

### 4.3.3 Connection Diagrams

Depending on the application a single magnetic vibrator (see figure 4-4) or up to 4 magnetic vibrators (see figure 4-5) can be operated with a single controller. Also the connection of a sensor with a AViTEQ controller of the type SRA... in special version with level scanning system or part overflow controller is possible.



*Unless the sensor isn't part of the AViTEQ supply, AViTEQ isn't responsible for the sensor selected and therefore further isn't liable for damages that result out of incorrect selection and an incorrect case of operation of a sensor that isn't permitted for the case of operation.*



*The following connection diagrams (image 4-4 and 4-5) apply to a combination of an AViTEQ magnetic vibrator with an AViTEQ controller. Further details referring to the connection of the controller and the magnetic vibrator are given in the operating manual for the respective AViTEQ-controller. If the magnetic vibrator is equipped with an oscillation sensor (PAL) and/or a temperature switch, the connection has to be carried out according to the information that are given in the operating manual for the respective AViTEQ-controller.*

*Using a controller from a third-party manufacturer, AViTEQ can not give any information about the operating behaviour of the magnetic vibrator. No warranty is given for damages that occur out of an improper combination of a controller from a third-party manufacturer with an AViTEQ magnetic vibrator.*



*Unsuitable controller, operation without controller and/or operation with the incorrect mains voltage/frequency normally result in damage to the magnetic vibrator and is not allowed. Ensure that the connected loads are correct and compare them with the device type labels!*



**ATTENTION!**

*It is totally prohibited that the current consumption of the magnetic vibrator exceeds the value of the nominal current specified on the type label, because this may lead to destroying the magnetic vibrator.*

For single drives the wiring has to be carried out as shown in figure 4-4 below.

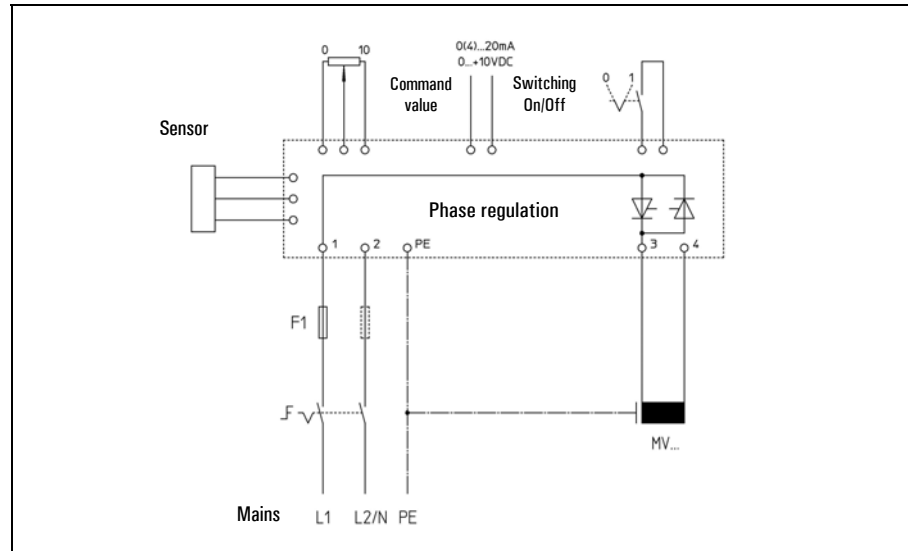

Figure 4-4 Connection diagram, single drive

If several magnetic vibrators (multiple drives) are operated with a common controller the wiring has to be carried out as shown in figure 4-5 below..

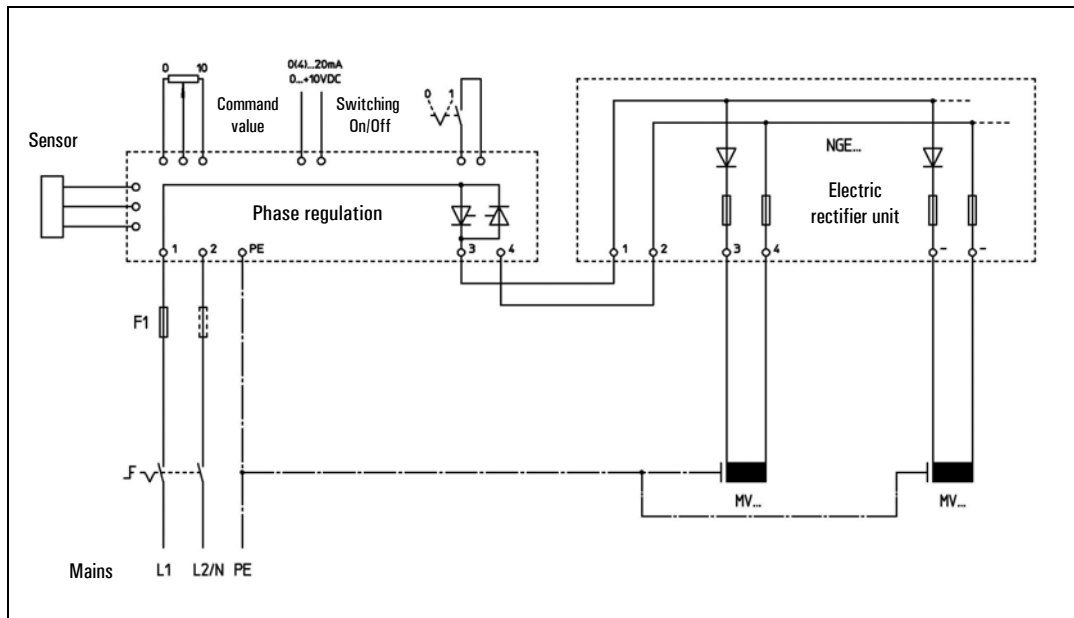

Figure 4-5 Connection diagram, multiple drives



**ATTENTION!**

*With multiple drives (s. figure 4-5) further an AVITEQ electric rectifier unit (NGE...) is required to avoid the magnetic vibrators effecting each other in a negative way!*

#### 4.3.4 Mains Connection



**DANGER!**

---

*Avoid accidents, observe regulations! Regulations and guidelines of your power company apply to the connexion of earth, neutral line, and protective circuitry! The connexion must be carried out only by qualified personnel (electricians or persons trained in electrical engineering according to EN 60204-1).*

*Switch off the mains supply, check that no voltage is present and protect against unintentional reconnexion!*

---



**NOTE**

---

*Magnetic vibrators of the series MV... must only be operated with an appropriate controller. Basic connection diagrams are part of this operating manual and are shown in chapter 4.3.3. . Please also observe the details referring to the connection of the controller that are given in the operating manual for the respective AViTEQ-controller.*

---

## 5 Commissioning

Prior to the first commissioning all assembly works have to be carried out, as they are described in the previous chapter.



**DANGER!**

*Before first commissioning, make sure that the vibration (conveyor) device can oscillate without colliding with other parts and that all screws are tightened correctly.*

AViTEQ delivers magnetic vibrators including the appropriate controllers. Before commissioning, please check that the magnetic vibrator is only operated with a matching (AViTEQ)-controller!



**DANGER!**

*Magnetic vibrators in normal version without an ATEX-type examination certification **must not** be operated in areas with potentially explosive atmospheres consisting of a gas-, a vapour-, a mist- or a dust-air-mixture!*



**ATTENTION!**

*Unsuitable controller, operation without controller and/or operation with the incorrect mains voltage/frequency normally result in damage to the magnetic vibrator and is not allowed. Ensure that the connected loads are correct and compare them with the device type labels!*

The commissioning procedure must be carried out using the lowest working stroke: Turn the vibration-width adjuster (potentiometer) on the controller counter clockwise till you reach the end stop (scale value of 0) or, if you use an external command value, set the lowest command value. Now switch on the controller.



**NOTE**

*The commissioning process is carried out at a low working stroke in order to be able to detect any damage caused by assembly errors or the vibration behaviour of the entire vibration (conveyor) device, which is undetected at this point. Example: The working unit collides with neighboring conveyor components or works in collision mode.*

Listen for any *hammering* noises that indicate the *collision mode*.

Slowly increase the working stroke by gradually turning the vibration-width adjuster (potentiometer) or by increasing the external command value, until the maximum value has been reached.



**NOTE**

*Even if the maximum command value (control input) is not used later in actual operation, you should test this position as well during commissioning to ensure that the vibration (conveyor) device operates cleanly at its limits.*

If hammering noises or resonances of the working unit or the support structure occur, switch off the unit and check the cause. By measuring the current and the voltage on the terminals of the controller, you can check the appropriate values. The maximum allowed vibrator voltage that is shown on the related characteristics curve data sheet for the respective mains voltage **must not** be exceeded!





**DANGER!**

---

*Short circuit or danger of electrocution during the following measurements! Observe the safety regulations when measuring voltage-carrying components! Take appropriate measures to prevent contact with voltage-carrying components.*

---



**NOTE**

---

*Only use meters which display the root mean square value for measuring the voltage and the current (moving iron instrument or „true RMS“). Other measuring devices would not produce relevant measurements when measuring the non-sinusoidal voltage or current curve. For digital measuring devices, select a measuring range of  $\geq 750\text{ V}$ !*

---

The current that is shown on the type label must not be exceeded!

If no problems appeared, please check the function of the magnetic vibrator with the appropriate transported material for completing the commissioning: Is the material transported uniformly? Measure whether the required throughput is achieved.

Did problems appear while commissioning or do you have any questions, give us a call. We'll be glad to help you.

## 6 Maintenance



**DANGER!**

*Before carrying out any inspection works, the magnetic vibrator must be disconnected from mains and protected against reconnecting. Check that no voltage is present! Further check, if the surface temperature is less than +50°C, otherwise the surface temperature may lead to burns of the skin!*



**ATTENTION!**

*Changes of the air gap, the spring rate, the tightening torque of the spring mounting screws and/or operating the magnetic vibrator with an incorrect natural frequency (...observe characteristics curve data sheet) are not allowed, because this may lead to excessive heating of the drive, to short circuits between electromagnet windings, and eventually to the destruction of the drive.*

### 6.1 Regular Checks

We recommend the following checks in regular intervals as shown below:

Test intervals	Checks
2 operating hours after the first commissioning	<ul style="list-style-type: none"> <li>- Check screw connections (working unit/drive)</li> <li>- Check, if connection cable doesn't swing</li> <li>- Check, if connection cable shows visible damages</li> <li>- Check noise development</li> <li>- Check that no deposits are existing (working unit)</li> </ul>
24 operating hours after the first commissioning	<ul style="list-style-type: none"> <li>- Check screw connections (working unit/drive)</li> <li>- Check, if connection cable doesn't swing</li> <li>- Check, if connection cable shows visible damages</li> <li>- Check noise development</li> <li>- Check that no deposits are existing (working unit)</li> <li>- Check the condition of the support elements (rubber (hollow) pads)</li> <li>- Check the condition of the working unit</li> <li>- Check the natural frequency</li> </ul>
weekly	<ul style="list-style-type: none"> <li>- Check, if connection cable doesn't swing</li> <li>- Check, if connection cable shows visible damages</li> <li>- Check noise development</li> <li>- Check that no deposits are existing (working unit)</li> </ul>
monthly	<ul style="list-style-type: none"> <li>- Check screw connections (working unit/drive)</li> </ul>
half-yearly	<ul style="list-style-type: none"> <li>- Check the condition of the support elements (rubber (hollow) pads)</li> <li>- Check the condition of the working unit</li> <li>- Check the natural frequency</li> </ul>

Table 6-1 Regular checks

## 6.2 Cleaning

Depending on the environmental condition and the properties of the material transported, the components of the vibration (conveyor) device, in particular the working unit, will be subject to varying degrees of contamination. Check the contamination level on regular basis. Initially, check on a weekly basis, thereafter check in intervals that you determine based on the requirements.

If the contamination is significant enough to impair the throughput, cleaning is required. As cleaning methods, alongside mechanical methods (hand brush e.g.), pressurised air and water with and without chemical cleansing agents are allowed.

Proceed thereby as follows:

- ☞ Switch off the power to the drive before any cleaning operation!
- ☞ Select the appropriate method! If applicable, follow the guidelines for the use of pressurised air, water and cleaning solvents that apply to the installation site! Also observe the degree of protection and take appropriate steps to avoid water intrusion into the terminal box.
- ☞ Only use cleaning solvents with a pH value of 7 or greater!
- ☞ Do not use cleaning solvents containing chlorine!
- ☞ When cleaning with compressed air, observe any in-house regulations regarding dust!



**ATTENTION!**

*Detachment of paintwork and contamination of the transported material! Do not use aggressive agents that could damage the paintwork! In the food processing industry, only permitted cleaning agents and solvents may be used. Do not use cleaning agents that may attack the plastic insulation of cables and cable glands!*

- ☞ Remove all residues of transported material and cleaning agent after cleaning!

## 6.3 Repairs

In the event of damage, please send the magnetic vibrator back to AViTEQ Vibrationstechnik GmbH, 65795 Hattersheim-Eddersheim, Germany for being repaired. We advise against repairing the magnetic vibrator by yourself, unless you haven't been trained and authorised by AViTEQ.



**NOTE**

*The magnetic vibrators for standard areas are only allowed to be repaired by AViTEQ Vibrationstechnik GmbH or by special staff that has been trained and authorised by AViTEQ. AViTEQ Vibrationstechnik GmbH is not liable for damage to property and/or person in the case of neglect!*

# 7 Troubleshooting

In the following table you will find information regarding possible faults which could occur during installation or during operation.

	Fault	Cause(s)	Remedy
①	Drive does not function	No mains voltage	Check fuse(s) and the supply line(s)
		Units (controller, magnetic vibrator) defect	Please send the units to AViTEQ Vibrationstechnik GmbH, we will check and if possible repair the units
②	Open fuse	Power input of the magnetic vibrator inadmissibly highly	Observe point ③
③	Power input of the magnetic vibrator inadmissibly highly	Defect coil (electromagnet)	Please send the unit to AViTEQ Vibrationstechnik GmbH, we will check and if possible repair the magnetic vibrator
		Air gap is set to wide	Only AViTEQ Vibrationstechnik GmbH is allowed to alter the air gap, please send in the unit or ask for our service
		Working weight to low and therefore natural frequency to high	Observe the characteristics curve data sheet and tune to the correct natural frequency by adding weight to the inoperative side
④	Drive is running in collision mode (hammering noise)	Operating the magnetic vibrator without a controller	Only operate the magnetic vibrator with the appropriate controller
		Screws are loose	Tighten screws immediately with the appropriate torque to avoid damage to the magnetic vibrator and/or the vibration (conveyor) device
		Working weight to large and therefore natural frequency to low	Observe the characteristics curve data sheet and tune to the correct natural frequency by taking away weight from the inoperative side
		Deposits of the transported material result in a to low natural frequency	Eliminate deposits and take further steps to avoid deposits
		Air gap is set to narrow	Only AViTEQ Vibrationstechnik GmbH is allowed to alter the air gap, please send in the unit or ask for our service
		Wrong controller chosen	Please check, if the controller and the magnetic vibrator match, therefore check the AViTEQ delivery information.
		Leaf spring(s) or spring mountings screw(s) broken	Please send the drive to AViTEQ Vibrationstechnik GmbH, we will repair the magnetic vibrator
		Loose parts collide with the magnetic vibrator or unit	Remove or tighten loose parts immediately
⑤	Output (capacity) to low	Wrong controller chosen	Please check, if the controller and the magnetic vibrator match, therefore check the AViTEQ delivery information
		Working weight to low and therefore natural frequency to high	Observe the characteristics curve data sheet and tune to the correct natural frequency by adding weight to the inoperative side
		Working unit can not vibrate freely	The working unit must oscillate freely without touching any components, take appropriate steps
		Resonances at the working unit or the support construction	Eliminate resonances
		Deposits of the transported material, also ④ possible	Eliminate deposits and take further steps to avoid deposits
		Temperatures below 0°C, transported material freezes or sticks	Warm up the transported material if possible or take other steps to avoid that the material freezes or sticks

Table 7-1 Fault, Causes, and Remedies



**NOTE**

*Consult us, however, prior to performing error rectification measures to avoid possible damages or accidents.*

*The faults listed in the table 7-1 mainly refer to the magnetic vibrator. Further faults, caused by the controller, can be found in the appropriate operating manual.*

## 8 Index

**A**mbient temperature, allowed 11  
Auxiliary weight "Gz" 16, 18

**C**haracteristics curve data sheet 18, 19  
Checks, regular 34  
Cleaning 35  
Climate environments 11  
Collision mode 32  
Commissioning 32  
Conditions of delivery , domestic and abroad 6  
Conditions of warranty 9  
Connection cable 29  
Connection diagram(s) 29  
Content 7  
Controller(s) 8, 28  
Copyright 6

**D**eclaration of Conformity 38  
Device specification 16  
Disposal 15

**EC**-Directives 13  
Electric rectifier unit 30  
Electromagnet 16  
Extent of delivery 14

**F**ixing screws 24  
Food industry 11  
Frequency meter 17, 27

**H**ole dimensions 20,21  
Housing sizes 20, 21

**I**noperative side 16  
Intended use 2  
Installation 23, 25  
Installation personnel 12

**L**eam spring(s) 16  
Limit current 5  
Line lengths 29

**M**agnetic vibrator 8, 16  
Mains connection 28, 31  
Mains voltage 19  
Maintenance 34  
Manufacturer's Declaration 39  
Materials used in the unit 15  
Measuring the natural frequency 17, 27

**N**ominal current 5

**O**perating personnel 12  
Operative range 11

**P**acking materials 15  
Product liability 9

**R**ated current 5  
Repairs 35  
Returning the device 15  
Rubber (hollow) pads 16

**S**afety notes 3  
Safety precautions 12  
Screw length 24  
Screw tightening torques 25  
Separate ventilation 22  
Sizes 20  
Sound pressure level 5, 22  
Storage 14

**T**ransport 14  
Troubleshooting 36  
Tuning of the oscillation system 17  
Type designation 20

**V**ibration (conveyor) device 8  
Vibrator collision voltage 19  
Vibrator nominal voltage 19

**W**arranty 9  
Warranty exclusions 9  
Working side 16  
Working unit 8, 16, 23  
Working weight „Gn“ 18

---

# Declaration of Conformity

*according to Appendix III Point B of the EC Directive 2006/95/EC for electrical equipment designed for use within certain voltage limits*

The Manufacturer...

**AVITEQ Vibrationstechnik GmbH  
Im Gotthelf 16  
65795 Hattersheim-Eddersheim  
Germany**

declares that the magnetic vibrators of the series...

**MV...**

are in conformance with the following European Directive...

**2006/95/EC**

**Directive relating to electrical equipment  
designed for use within certain voltage  
limits**

The conformance of the products with the European Directive is demonstrated through full observation of the following harmonised standards and national standards:

**EN 60204-1**

**DIN IEC 60038  
DIN VDE 0580**

*Full technical documentation is available. The operating manual for the devices has to be observed. The CE symbol has been placed on the type label of the magnetic vibrator.*

The safety notes in the operating manual and the intended use must be observed! This declaration certifies conformance with the specified standards and directive . It does not, however, include a guarantee of characteristics.

Hattersheim-Eddersheim, 8<sup>th</sup> of October 2008

Legally binding signature:

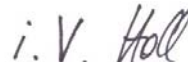

---

i.V. Holl (Product Manager for Magnetic Vibrators)

# Manufacturer's Declaration

according to Appendix II B of the EC Directive 98/37/EC relating to machinery

The Manufacturer...

**AViTEQ Vibrationstechnik GmbH  
Im Gotthelf 16  
65795 Hattersheim-Eddersheim  
Germany**

declares that the magnetic vibrators of the series...

**MV...**

are in conformance with the following European Directive...

**98/37/EC**

**Directive relating to machinery**

The conformance of the products with the European Directive is demonstrated through full observation of the following harmonised European and (Inter)national Standards:

**EN ISO 12100-1 / ...-2  
EN 294  
EN 563  
EN 60204-1  
EN 60529**

**DIN VDE 0580**

Full technical documentation is available. The operating manual for the devices is in hand. **Commissioning of the magnetic vibrator is prohibited until it is established that the machine with which the magnetic vibrator will be completed complies with the regulations of the machinery directive 98/37/EC!**

The safety notes in the operating manual and the intended use must be observed! This declaration certifies conformance with the specified standards and directive . It does not, however, include a guarantee of characteristics.

Hattersheim-Eddersheim, 8<sup>th</sup> of October 2008

Legally binding signature:

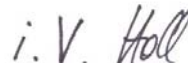

---

i.V. Holl (Product Manager for Magnetic Vibrators)

AViTEQ Vibrationstechnik GmbH  
Im Gotthelf 16  
65795 Hattersheim-Eddersheim  
Germany

Phone ..... +49 / (0) 61 45 / 5 03 - 0  
Fax ..... +49 / (0) 61 45 / 5 03 - 2 00  
Fax ..... +49 / (0) 61 45 / 5 03 - 112 (Service-Hotline)  
E-Mail ..... [service@aviteq.de](mailto:service@aviteq.de)

[www.aviteq.de](http://www.aviteq.de)

 VIB 12.50 / 10-2008 EN (BE)