



Operating Manual

VIBTRONIC® Controllers for Magnetic Vibrators

Series SRA(E)...-1
as Panel Mounting Units and Cabinet Units

Control and Display Elements

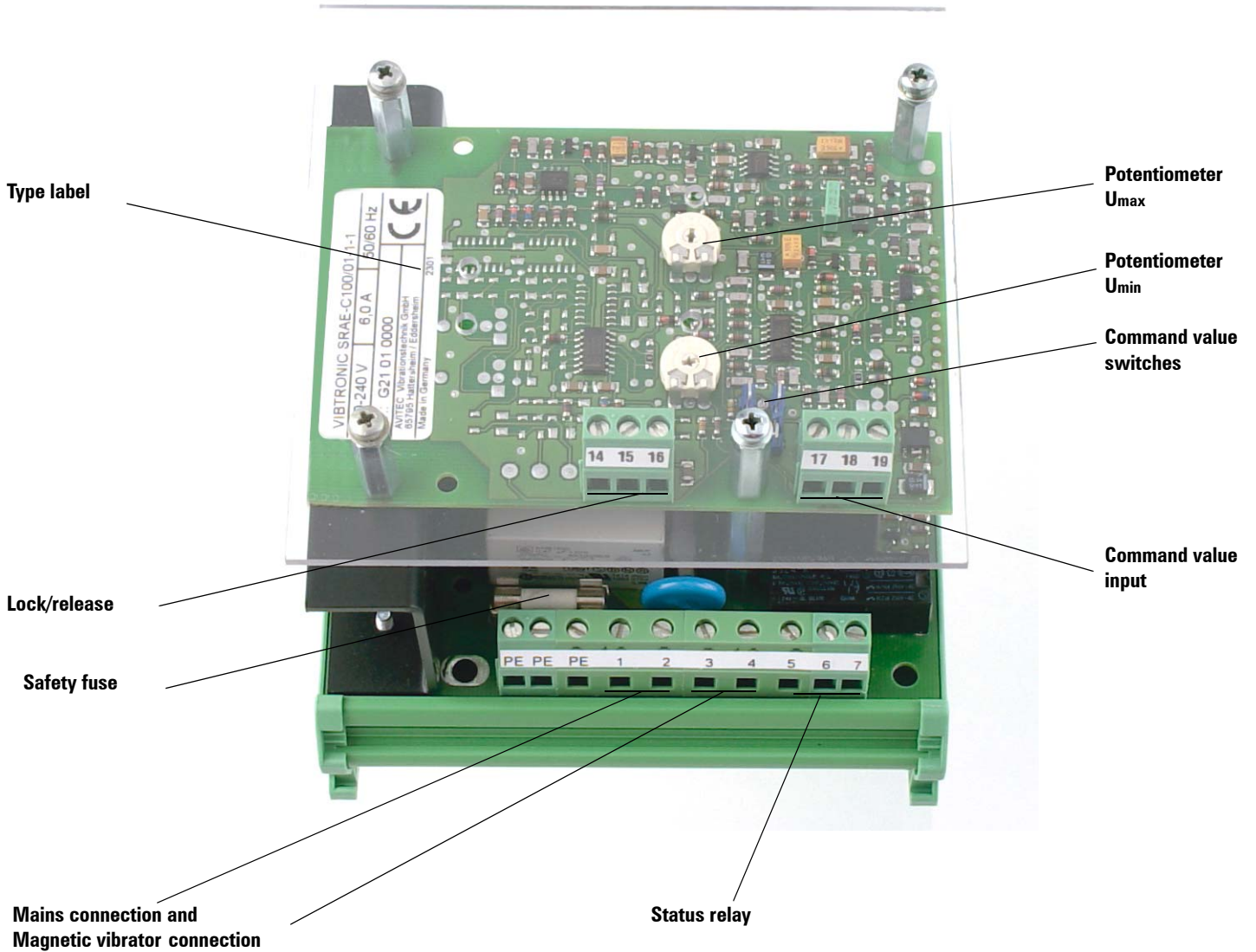

Intended use

The VIBTRONIC SRA(E)... -1 type controllers have been designed and constructed as alternating voltage regulators for controlling small-parts conveyor drives, bowl feeder drives magnetic drives in industrial plants. They operate according to the principle of voltage regulation (phase regulation).

The controllers have been designed for use on a.c. mains networks with a frequency of either 50 or 60 Hz and a sinusoidal voltage.

Do not use the controllers in environments with a risk of explosion or firedamp. Observe the information regarding the areas of application given in Chapter 1.3.

For your safety

Labelling

This operating manual contains three different types of instructions which point out important information:



DANGER!

.....
The DANGER warning describes procedures or conditions which could result in dangerous or even fatal consequences for the person installing or using the equipment.
.....



ATTENTION!

.....
These instructions are given for procedures where there is a danger of damage to equipment. However, personal injury may also occur as a result (e.g. in the event of a fire!)
.....



NOTE

.....
Notes provide information about specific procedures. Notes explain circumstances, clarify terminology or provide tips for simplifying processes or procedures.
.....

Always observe the accident prevention and safety regulations which apply to the specific area of use.

Important points on dangers

Although the VIBTRONIC controllers have been developed in accordance with all safety measures, the possibility of operational error cannot be completely excluded. In the interest of your safety and that of your colleagues, please observe the following points:



When connected to the mains, there are dangerously high voltages within the controller. Touching electrically live components can be fatal! Before switching on the mains power, ensure that it is not possible to touch any live parts. The electrical connections must be covered!



Disconnect the supply voltage before conducting any work on the controller or when replacing a fuse. Observe the applicable regulations from the relevant liability insurance organisation. Following assembly, check that the protective conductor connections are functioning correctly.



Explosions can be fatal and result in significant damage to equipment. Do not use the controller in environments where there is a risk of explosion. SRA(E)...-1 type controllers have not been designed for environments with explosion hazards or firedamp environments and must not be used in such areas without first taking appropriate measures.



Unsuitable controllers or operation with the incorrect mains voltage/frequency could result in damage to the small-parts conveyor drive or bowl feeder drive. Ensure that the connected loads are correct and compare them with the device type labels!



The controller is fitted with a quick-acting safety fuse (F6.3 A / 250 V) for protecting the Triac (see also first inside cover page). In case of replacing the fuse, always use a quick-acting safety fuse of the same type as the controller may otherwise be destroyed!

©2001 AViTEQ Vibrationstechnik GmbH

COPYRIGHT

The SRA(E)... -1 series VIBTRONIC controllers and this operating manual are protected by copyright. Any reengineering of the units will result in criminal prosecution. All rights to this operating manual are reserved, including reproduction via photo-mechanical, printing, or any data medium, including in translation.

Reproduction of this operating manual, complete or in part, requires written consent from AViTEQ Vibrationstechnik GmbH.

VIBTRONIC is a registered and protected trademark of AViTEQ Vibrationstechnik GmbH.

This operating manual supports the intended use and the appropriate operation of VIBTRONIC controllers. For this purpose, the operating manual includes information relating to the use of the product. In particular, the operating manual does not represent any assurance of specific features or that certain results will be achieved by the use of the product. Prior to publication, this operating manual has been subjected to thorough verification. AViTEQ Vibrationstechnik GmbH shall only be liable for mistakes in the content of this operating manual in cases of intentional or gross negligence. This liability shall be restricted to cases where mistakes in the content render the product worthless or useless, or considerably reduces its value or usability, for its usual purpose or any purpose covered by the contract.

Evidence of mistakes in the content, the damage and the causality regarding both cause and extent of the claim, must be provided by the purchaser. AViTEQ Vibrationstechnik GmbH shall not be liable for damage or consequential damage resulting from the use of the operating manual. This shall not apply to mistakes in the content of the operating manual. We are always grateful to receive suggestions and criticism.

Unless otherwise stated, the technical status at the time of the combined delivery of the product and the operating manual from AViTEQ Vibrationstechnik GmbH shall be regarded as definitive. The product is subject to technical modification without prior notice. Previous operating manuals shall no longer be valid.

The current version of the General Terms and Conditions for Domestic and Foreign Deliveries from AViTEQ Vibrationstechnik GmbH shall apply, unless otherwise agreed.

Do you have any queries? Or any problems with installation and commissioning?
Give us a call! We'll be glad to help you!

AViTEQ Vibrationstechnik GmbH

Im Gotthelf 16

65795 Hattersheim-Eddersheim

Telephone +49 (0) 61 45 / 503 - 0

Fax +49 (0) 61 45 / 503 - 200

Fax Service Hotline +49 (0) 61 45 / 503 - 112

Hattersheim-Eddersheim, Germany, 6. February 2002



CONTENTS

1	We are Partners.	1-1
1.1	About this operating manual	1-1
1.2	Product liability and warranty	1-2
1.3	Operative range	1-3
1.4	Installation and operating personnel	1-4
1.5	Repairs.....	1-5
2	Transport, Delivery, Disposal	2-1
2.1	Transport, storage.....	2-1
2.2	Extend of delivery	2-1
2.3	Disposal	2-2
3	Equipment description	3-1
3.1	Oscillation and mains frequency	3-1
3.2	Scope of operation.....	3-1
3.2.1	Command value specification	3-1
3.2.2	External release	3-2
3.2.3	Operating messages	3-2
3.3	Series and versions.....	3-2
3.3.1	VIBTRONIC-series	3-2
3.3.2	Versions and technical data	3-3
3.3.3	Type designations	3-4
4	Installation	4-1
4.1	Mechanical installation	4-1
4.1.1	Panel mounting unit	4-1
4.1.2	Cabinet unit.....	4-2
4.2	Terminal assignments	4-3
4.2.1	Minimum terminal assignments.....	4-4
4.2.2	Course and fine fill rates	4-6
4.2.3	External control input.....	4-6
4.2.4	Switching on/off externally	4-8
4.2.5	Status relay.....	4-9
4.3	Electrical connection.....	4-10
4.3.1	Notes on electrical connections.....	4-10
4.3.2	Vibration- with adjuster, rotary-type knob and scale.....	4-11
4.4	Connection to the magnetic drive	4-11
4.4.1	Electromagnetic compatibility(EMV).....	4-12
4.4.2	Line lengths	4-12
5	Commissioning	5-1
5.1	AVITEQ-Magnetic drives	5-1
5.2	Third party drives.....	5-1
5.2.1	Setting the nominal vibrator voltage	5-1
5.2.2	Commissioning, step-by-step	5-2
6	Maintenance	6-1
7	Fault causes and remedies	7-1
8	INDEX	i

1 We are Partners.

1.1 About this operating manual

This operating manual is intended for

- installation technicians installing and commissioning the small-parts conveyor drive or bowl feeder drive or magnetic vibrator.
- engineers installing the controller, the electrical connection to the a.c. mains network and the connection to the small-parts conveyor drive or bowl feeder drive or the magnetic vibrator.

All work on the controller must only be carried out by qualified specialist staff (electricians or persons trained in electrical engineering in accordance with IEC 364 and EN 60204-1).

Definitions

- *Small-parts conveyor drive or bowl feeder drive, magnetic vibrator (shortened to: drive or magnetic drive):* electromagnetic-mechanical unit for operating a vibration conveyor device
- *Vibration conveyor device:* unit consisting of the drive and working unit (trough, tube, helical conveyor, screen, etc.)
- *Controller:* the electronic control unit (supplied separately) assigned to the drive for connecting to the a.c. mains network
- *Cabinet unit:* Controller in compact housing for wall or frame mounting (type SRA... -1)
- *Panel mounting unit:* Controller for installation in a switching cabinet or an enclosed control location (type SRAE... -1)



NOTE

Revision date

The version number at the bottom of each right-hand page in this operating manual gives the date when that page was last updated.

This operating manual relates to the panel mounting unit. Variations specific to the cabinet unit are indicated at the appropriate points.

Special symbols in this operating manual

Given earlier in this manual is a description of how safety information is indicated in the text. If you have any questions about safe working practices regarding controllers and their environment, please call us. We'll be glad to help you!

For your convenience and ease-of-use, we use the following special symbols in this operating manual:

- A round dot indicates a list of features and conditions
- ☺ A "thumbs up" symbol indicates that something needs to be checked.

☞ A pointing finger indicates steps that must be carried out.

1.2 Product liability and warranty

The controllers represent the state-of-the-art and all the specified functions have been tested prior to delivery. AViTEQ Vibrationstechnik GmbH carries out product and market research to aid further development and ongoing improvement. Should malfunctions or failures occur despite these preventive measures, please contact our service department. We guarantee that appropriate measures to repair the fault will be taken immediately.

Warranty conditions

We guarantee the functioning of the product as described in this operating manual for a period of 12 months after the date of delivery as stated on the delivery note. The condition for free repair is adherence to the operating manual when storing, shipping, installing, commissioning and operating the product.

We guarantee that the product is free of faults according to product information published by us, and according to the relevant specifications in this operating manual. No further product features are guaranteed. AViTEQ Vibrationstechnik GmbH accepts no responsibility for the efficiency of the product or for fault-free operation if used for other purposes than those defined on the first right-hand inside cover page of this operating manual.

Warranty exclusions

Customers and third parties must consult AViTEQ Vibrationstechnik GmbH and obtain our written consent before tampering or otherwise interfering with the product covered by the contract. Otherwise, AViTEQ Vibrationstechnik GmbH shall not accept liability for resultant damage to equipment, injuries and other consequential damage to the product covered by the contract or to any other property. Tampering or interfering with the equipment shall also render any warranty null and void.

AViTEQ Vibrationstechnik GmbH shall not accept liability beyond the warranty entitlements stated in our terms of business on which the contract is based. This applies in particular to claims arising from loss of profit or other damage to customer assets. This restriction shall not apply if the cause of the damage results from intentional or gross negligence. Neither shall it apply if the customer's claim for damages is based on the lack of a promised feature. If an obligation under the contract is violated by negligence, AViTEQ Vibrationstechnik GmbH's liability shall be limited to foreseeable damage.

The warranty shall be null and void in particular if the equipment is used in environments, for purposes, or connected to power supplies or to control systems which are not suitable for the controllers or which do not conform to standard levels of up-to-date technology. In particular, liability shall not be accepted for any damage resulting from unsuitable or improper use, faulty installation by the customer or third parties, normal wear and tear, incorrect or negligent handling or

The
*General Terms and Conditions
for Domestic and Foreign
Deliveries*
from AViTEQ Vibrationstechnik
GmbH shall apply in its current
version, unless otherwise
agreed.

inappropriate operating materials. The same applies to spare parts, chemical, electrochemical or electrical influences unless the damage can be attributed to AViTEQ Vibrationstechnik GmbH. Compensation for damage other than damage to the product covered by the contract is excluded except in cases of intentional or gross negligence or the culpable violation of primary contractual obligations by AViTEQ Vibrationstechnik GmbH.

In addition, no liability shall be accepted for damage to conveyor and automation plants caused by a malfunction of the product or by mistakes in the content of the operating manual. No liability shall be accepted for damage caused by accessories not supplied or certified by AViTEQ Vibrationstechnik GmbH. AViTEQ Vibrationstechnik GmbH shall not be held responsible for the violation of patent rights or other rights of third parties outside the Federal Republic of Germany.

We would like to stress that no liability for damage to the product covered by the contract, or for consequential damage to other property shall be accepted if the damage is caused by non-compliance with safety regulations and/or warning notices.

In concluding the contract, the customer is obliged to state explicitly if the product covered by the contract is intended for private use and will be used by the customer predominantly for this purpose.

The VIBTRONIC controllers described in this operating manual must not be operated in the United States of America or other countries where US American law applies, without informing AViTEQ Vibrationstechnik GmbH.

1.3 Operative range

Type SRA(E)...-1 VIBTRONIC controllers are electrical devices for use in industrial plants and are used to control vibration conveyor devices. The controllers permit the infinite adjustment of the working stroke on magnetic drives and therefore also the output of vibration conveyor devices.

The controllers must be used together only with AViTEQ small-parts conveyor drives or bowl feeder drives or the corresponding magnetic drives produced by other manufacturers in accordance with their intended use. Information in the operating manuals for the vibration conveyor device and the magnetic vibrator must also be observed.

The controllers can be operated with magnetic drives from external manufacturers assuming it has been guaranteed that the controller and the magnetic drive are equipped for the mains voltage and mains frequency specified on the type label.



NOTE

The current of the third party magnetic drive must never be greater than the current for which the controller has been equipped, as given on the type label. If in doubt, please contact us! The commissioning procedure is described in chapter 5.2.

Danger

Never use in the following situations:

- *Do not use* for operation in environments with a risk of explosions or firedamp (explosives, environment containing gas, danger of dust explosions). The units are not protected against explosion. The level of contamination in the environment must not exceed *level 1* conforming to IEC 664.
- *Do not use* at ambient temperatures less than -5 and over +45 °C (cabinet controller unit or panel mounting controller unit), and in tropical climatic conditions or any condensation (relative air humidity less than 93 % without condensation or surface water formation). The units are designed for operation in moderate climatic environments. The storage temperature must be within the limits of -20 and +70 °C.
- *Do not use* in combination with small-parts conveyor drives or bowl feeder drives, for which the controllers are unsuitable.
- *Do not use* on mains networks and mains frequencies for which the controllers are unsuitable.



NOTE

The controllers are designed for use at a maximum height of 1000 m above mean sea level. For each additional 100 m of starting height, the nominal current is reduced by 0.5 %!

Connection to mains and to small-parts conveyor drives or bowl feeder drives

AViTEQ small-parts conveyor drives or bowl feeder drives may only be operated via the AViTEQ controllers on sinusoidal a.c. mains networks. There is a specific controller for each AViTEQ small-parts conveyor drive or bowl feeder drive model.

Other control and connection options are not included.



ATTENTION!

If a magnetic drive is connected directly to the mains or if an inappropriate controller is used, the magnetic drive may be destroyed. Ensure that the appropriate controller is used.

Prior to installation and/or commissioning, you should familiarise yourself with all the specifications for the controller and with the connection options of the magnetic drive. Please also see the chapter on connecting the magnetic drives in the operating manual.

1.4 Installation and operating personnel

It is essential that persons involved in installation, commissioning, assembly, disassembly, adjustment or maintenance have read and understood this operating manual in its entirety, in particular the safety notes. If you have any questions, we will be glad to help!

All work on the controller must only be carried out by qualified specialist staff (electricians or persons trained in electrical engineering in accordance with IEC 364 and EN 60204-1). Personnel must have sufficient knowledge on the current

standards, regulations, accident prevention regulations and operating conditions to be authorised by the persons responsible for the safety of the plant to perform the necessary activities.

The controllers may only be serviced by authorised and service staff trained by AVITEQ Vibrationstechnik GmbH, Hattersheim-Eddersheim, Germany. AVITEQ Vibrationstechnik GmbH, Hattersheim-Eddersheim, Germany is not liable for injuries or damage to property if this condition is not met.

1.5 Repairs

The controller does not contain any components which can be serviced or repaired by the installation personnel or operator. Never open the equipment but send it to AVITEQ Vibrationstechnik GmbH, Hattersheim-Eddersheim, Germany in the event of a fault.

Please read chapters 6 and 7 if the controller is not functioning correctly.



.....
When connected to the mains, there are dangerously high voltages within the controller and the magnetic drive. Touching electrically live components can be fatal! Before switching on the mains power, ensure that it is not possible to touch any live parts.
.....

2 Transport, Delivery, Disposal

2.1 Transport, storage

- Delivery: The controllers and accessories are delivered in appropriate packaging to ensure that they reach their destination undamaged.

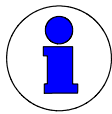

NOTE

If the packaging is visibly damaged indicating possible damage to the contents, please contact the courier. In further proceedings, please observe the general terms and conditions from the courier to avoid jeopardising your claim for damages due to improperly completed forms.

- ☞ Storage: Unless special agreements have been made concerning packaging and storage, the units whether packed or unpacked, must be stored and transported under "normal" conditions. This means enclosed rooms with temperatures between -20 and +70 °C, relative air humidity not to exceed 93 % (no condensation), and no mechanical shocks or vibrations.



ATTENTION!

Transportation and storage of the units in inappropriate conditions may cause irreparable damage. Such damage may not be visible externally. The warranty from AViTEQ Vibrationstechnik GmbH shall be void in this event, and shall not be liable for any consequential damage.

2.2 Extend of delivery

- ☞ After unpacking, check the delivery note and accompanying documentation to ensure that all the parts have been supplied and are undamaged. These parts include the panel mounting controller unit or cabinet controller unit itself, the operating manual packed together with the controller and for panel mounting units, the separate potentiometer for setting the working stroke with rotary-type knob and scale, and for cabinet unit controllers the relevant plug.
- ☞ Compare the information on the small-parts conveyor drive or bowl feeder drive type labels with the delivery note and order documentation.

- ☞ Check that the small-parts conveyor drive or bowl feeder drive and the controller match. Before using magnetic vibrators produced by other manufacturers, you must first ensure that the specifications are suitable for operation with the VIBTRONIC controller. If in doubt, please do contact us. We'll be glad to help you!



The small-parts conveyor drive or bowl feeder drive and controller may be destroyed if the combination is not permissible. The mains voltage, mains frequency and vibration frequency must be identical. The nominal current of the controller must be equal to or greater than the peak current of the magnetic drive. Only compatible devices may be connected.

2.3 Disposal

2

Specifications for packaging material

All packaging materials should be disposed of in accordance with local regulations at the delivery destination.

Equipment returns

AVITEQ Vibrationstechnik GmbH will accept without charge controllers of type SRA(E)... -1 delivered in 2001 or later when delivered shipping paid to AVITEQ Vibrationstechnik GmbH, Hattersheim-Eddersheim, Germany.

Specifications of materials used in the equipment

In the event of disposal by the customer, and when exchanging components, the relevant local waste and disposal regulations apply and must be observed. We can accept no responsibility for parts and components not disposed of properly.

- The regulations for the disposal of electronic parts and components apply to the disposal of the controller.
- The power semiconductors used (Triac and diode modules) do not contain beryllium.

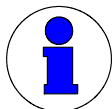

NOTE

More detailed information on the materials used is available from us on request. In case of doubt, please do make use of our recycling service.

3 Equipment description

3.1 Oscillation rates and mains frequency

Type SRA(E) ... -1 controllers are alternating voltage regulators and operate according to the principle of voltage regulation (phase regulation).



NOTE

.....
Oscillation rates are specified in "min⁻¹" and the oscillation frequency in "Hz".
.....

- Controllers for vibration conveyor devices with an oscillation rate of 3000 min⁻¹ (50 Hz) at a mains frequency of 50 Hz and 3600 min⁻¹ (60 Hz) at a mains frequency of 60 Hz are triggered at every second mains half-wave.
- Controllers for vibration conveyor devices with an oscillation rate of 6000 min⁻¹ (100 Hz) at a mains frequency of 50 Hz and 7200 min⁻¹ (120 Hz) at a mains frequency of 60 Hz are triggered at every mains half-wave.

The mechanical oscillation frequency (50, 60, 100 or 120 Hz) is factory set and encrypted in the type designation.

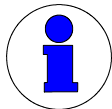

NOTE

.....
This new generation of controllers has been developed in accordance with the EMC Directive (89/336/EEC) and conforms to the requirements of EN 50081-1 and EN 50082-2.
.....

3.2 Scope of operation

Type SRA(E)... -1 VIBTRONIC controllers have been designed for voltage regulation. Mains voltage fluctuations have no significant effect on the working stroke or therefore on the conveying capacity across a wide range ($\pm 10\%$).

3.2.1 Command value specification

The command value for the working stroke can optionally be set using

- a vibration-width adjuster (potentiometer) or
- an external control input (0...10 V DC, 4...20 mA or 0...20 mA)



NOTE

.....
The working stroke changes virtually proportionally with the command value, i.e.: the greater the command value, the greater the working stroke.
.....

3.2.2 External release

The controller can be activated using an electronic release and therefore using a PLC (programmable logic controller), for example. This external release can be made using

- a potential-free contact or
- an external 24 V DC power source or
- an optical coupler.

3.2.3 Operating messages

With the cabinet unit, a green light will come on in the mains switch after the device is switched on.

3.3 Series and versions

3.3.1 VIBTRONIC series

Three series of VIBTRONIC controllers are available with different features:

- SRA(E)... series with voltage regulation in cabinet and panel mounting designs for nominal currents up to 6 A, operative ranges 110 and 230 V
- SC(E)... series with voltage regulation in cabinet and panel mounting designs for nominal currents up to 14 A, operative ranges 230, 400 and 500 V
- SD(E)... series with voltage and limit regulation in cabinet and panel mounting designs for nominal currents up to 50 A, operative ranges 230, 400 and 500 V

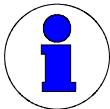

NOTE

.....
Only controllers in series SRA(E)...-1 are covered in this operating manual.
.....

3.3.2 Versions and technical data

The controllers are available in the following variants:

- SRA... cabinet unit (*IP 54*): enclosed compact housing for securing to walls or frames. Vibration-width adjuster and mains switch are fitted in the front of the housing.
- SRAE... panel mounting unit (*IP 00*): controller for installing in the switching cabinet or in closed control locations for top hat rail mounting

	SRA(E)-C50 ...-1	SRA(E)-C100 ...-1
Mains frequencies	50 or 60 Hz	
Oscillation rates in a 50 Hz mains network	3000 min-1 (50 Hz)	6000 min-1 (100 Hz)
Oscillation rates in a 60 Hz mains network	3600 min-1 (60 Hz)	7200 min-1 (120 Hz)
Mains voltages (Output voltage range)	105...115 V (20...100 V) 220...240 V (40...210 V)	
Output current	0.05...6 A	
Maximum power loss in switching cabinet	15 W	
Soft start	0.3 s or 1 s (can be factory set)	
Command value	Potentiometer 10 kOhm (lin), 0-10 V DC, 0-20 mA, 4-20 mA (adjustable)	
Status relay	Change-over contact 250 V AC / 30 V DC, 1.0 A	
Release input (factory specification)	Make contact or 24 V DC, can be inverted	

Technical data for the SRA(E)...-1 controllers



NOTE

The permissible tolerances are $\pm 10.0\%$ for the mains voltage and $\pm 0.5\%$ for the mains frequency.

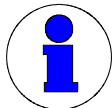

NOTE

The oscillation frequency is set at the factory before shipping and must not be changed by the customer.

3.3.3 Type designations



NOTE

The controllers are designed for different voltage ranges according to the table provided (Technical data). Please see the type label for the corresponding voltage range.

SRAE-C50/01-1-1

- Version number
- Version:
 - 1=no special functions
 - 2=level scanning system/part overflow controller
- Encryption of the mains voltage range
According to table:

Code	Mains voltage range
00	105...115 V
01	220...240 V

- Size and vibration frequency:
 - C50: 3000 / 3600 min⁻¹
 - C100: 6000 / 7200 min⁻¹
- Panel mounting unit
(Cabinet unit without "E")
- Device generation
- Controller, with voltage regulation

4 Installation

4.1 Mechanical installation

The installation steps for the two versions are described in the following sections:

- Panel mounting unit in chapter 4.1.1 and
- Cabinet unit in chapter 4.1.2

4.1.1 Panel mounting unit



The controllers are available as panel mounting units (IP 00 conforming to EN 60529) for vertical installation in switching cabinets or control cases (for dimensions, see diagram on next page). They comprise

- the panel mounting unit for top hat rail mounting (Type 35/7.5 EN 50022) and
- the potentiometer with rotary-type knob and scale (delivered loose).



Prior to installation: before opening the switching cabinet or control case, switch off the power supply, check that there is no voltage, and protect against accidental reconnection.

- ☞ Mount the panel mounting unit onto the top hat rail.
- ☞ Install the supplied potentiometer for working stroke adjustment with scale, rotary-type knob, pointer, and knob cover onto a suitable location (e.g. switching cabinet door or front of control case).



Controllers are sensitive to temperature. Ensure that the units are not installed near external heat sources, such as direct sunshine or radiators. The ambient temperature must not exceed +45 °C during operation.

- ☞ Observe the following minimum distances from neighbouring components:

Distance from ...	Minimum distance (mm)
top	40
bottom	80

Figure 4.1 Minimum distances from neighbouring components

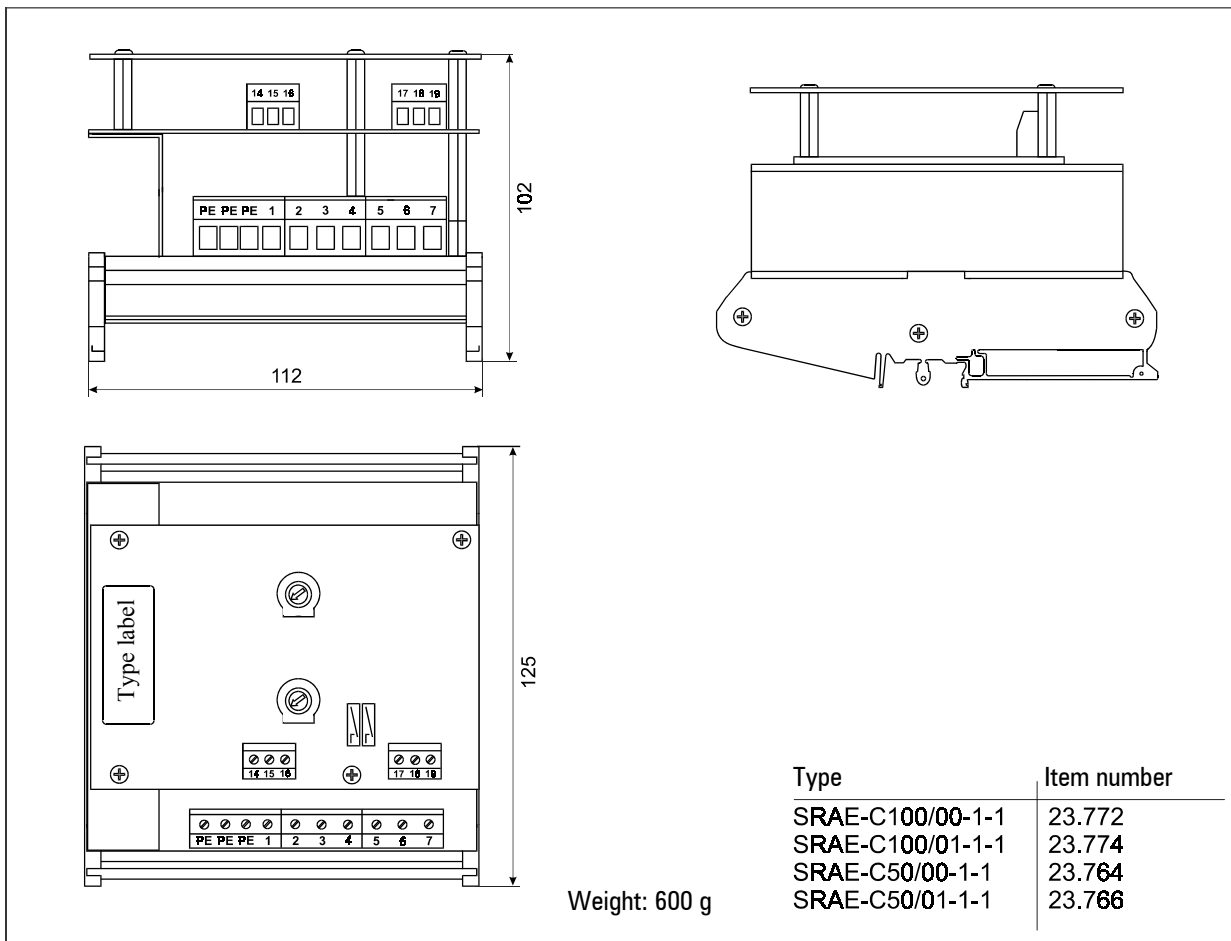

Figure 4.2 SRAE...-1 panel mounted version for fixing on a top hat rail.
Standard version

4.1.2 Cabinet unit



The controllers are supplied in a closed housing (IP 54 conforming to EN 60529). The cabinet unit is suitable for mounting to vertical walls or frames.

The installation is carried out as follows:

- ☞ Use the hole pattern on the dimensioned diagram below as a guide, and fix the relevant holes for the fixing screws.
- ☞ Hand-tightened the controller to a vibration-free vertical wall or frame.



ATTENTION!

Controllers are sensitive to vibration. Do not screw onto vibrating components, and under no circumstances to the vibration conveyor device itself.

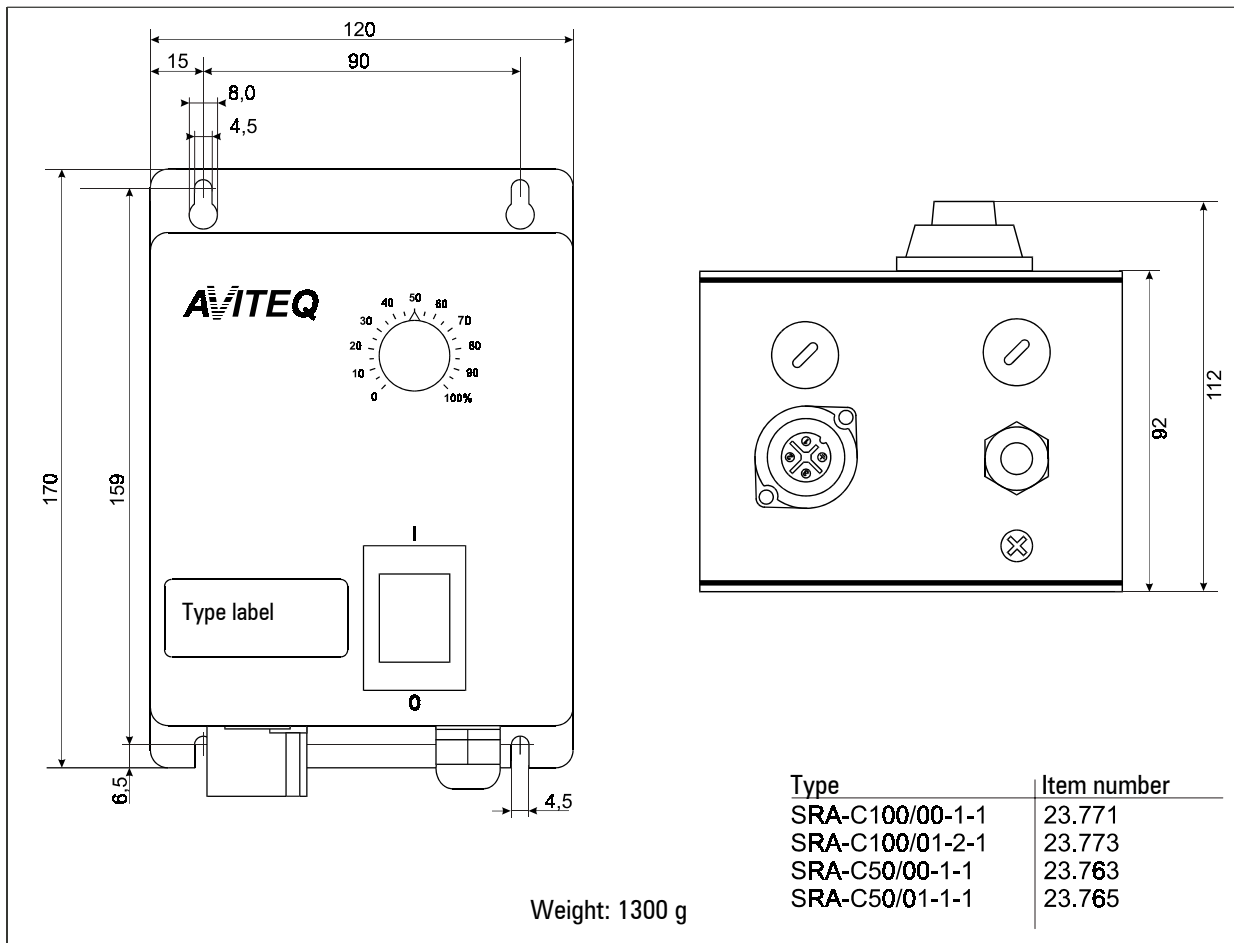

Figure 4.3 SRA...-1 cabinet unit design for mounting on vertical, vibration-free walls or frames
Standard version



.....
Controllers are sensitive to temperature. Ensure that the units are not installed near external heat sources, such as direct sunshine or radiators. The ambient temperature must not exceed +45 °C during operation.

4.2 Terminal assignments

The sections below explain the terminal assignments (see terminal plan below) on the controllers with the relevant options available. This chapter must be read before starting the wiring process, and the notes on electromagnetic compatibility must be observed.

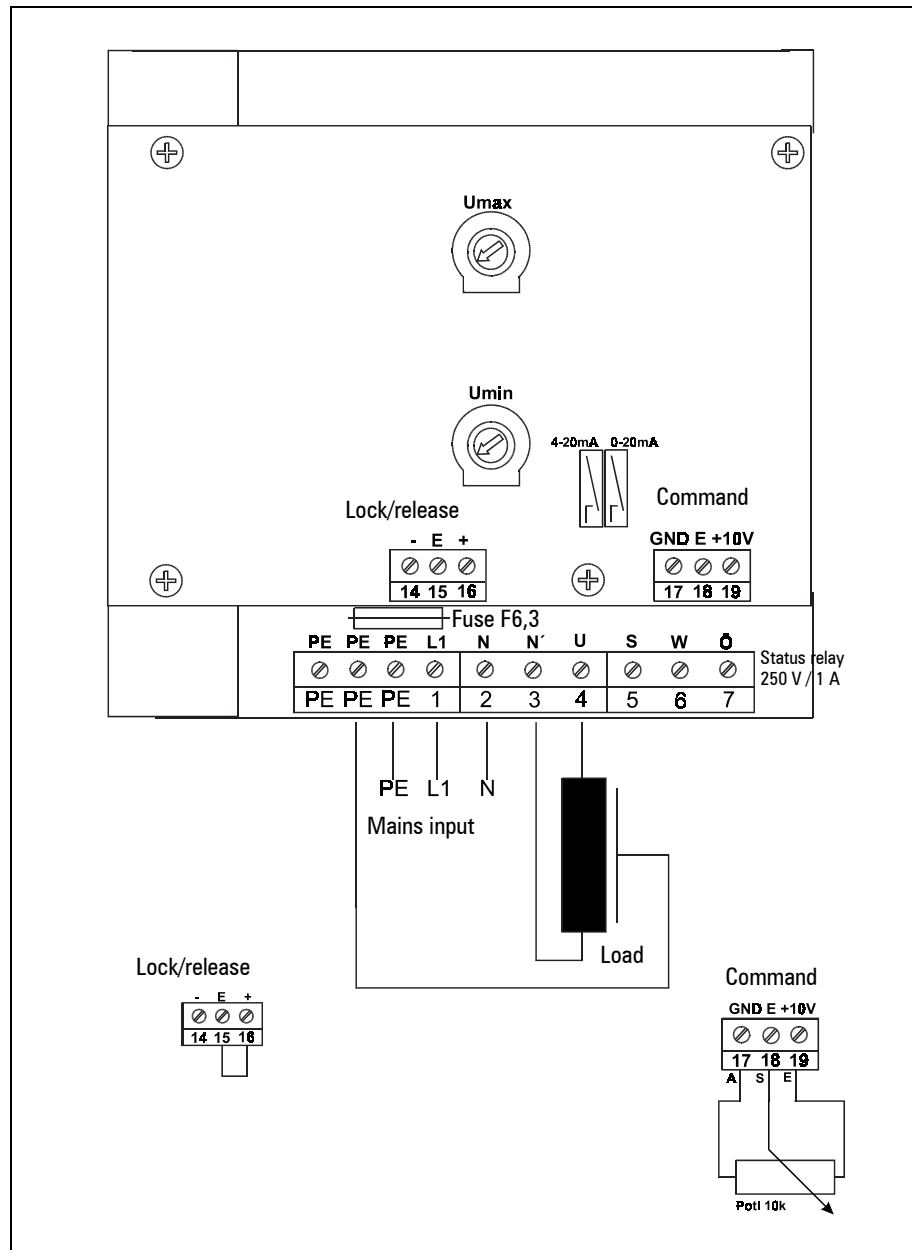

Figure 4.4 SRA(E)...-1 terminal plan
Standard version

4.2.1 Minimum terminal assignments

The minimum terminal assignments of a magnetic drive for voltage-regulated operation without external control inputs (for details see Chapter 4.2.3) shown in Figure 4.5.



NOTE

For operation without external release switch, terminals 15 and 16 must be connected by a wire bridge (Chapter 4.2.4). If there is no bridge, there will be no start signal and the magnetic drive will not function.

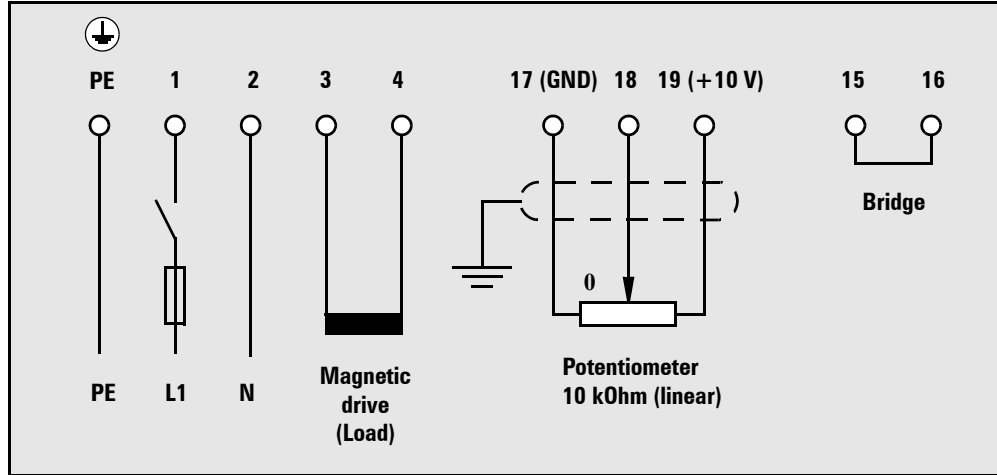

Figure 4.5 Minimum terminal assignments with mains input (terminals PE, 1 and 2), magnetic drive (terminals 3 and 4) and vibration-width adjuster (terminals 17, 18 and 19)

For the cabinet unit version, the plug connection assignments are as per Figure 4.6.

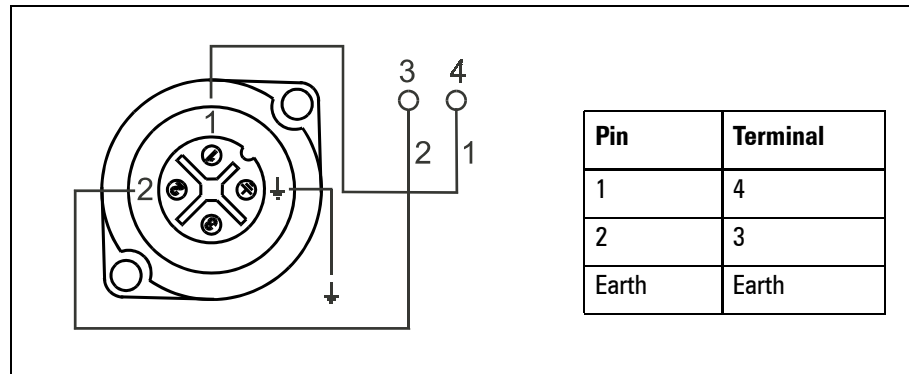

Figure 4.6 Plug connection assignments for the housing socket



NOTE

Only potentiometers (limit value 10 kOhm) with a linear characteristic should be used as a vibration-width adjuster. Shield the signal lines to guarantee electromagnetic compatibility if the lines exceed five metres in length.

4.2.2 Course and fine fill rates

When using the controller for metering and filling procedures, we recommend connection in accordance with Bild 4.7. In this circuit the two relays K1/K2 function as follows:

- K2 initiates the filling process.
- K1 is activated at 95% full weight.
- At 100% full weight, both relays return to their rest positions.

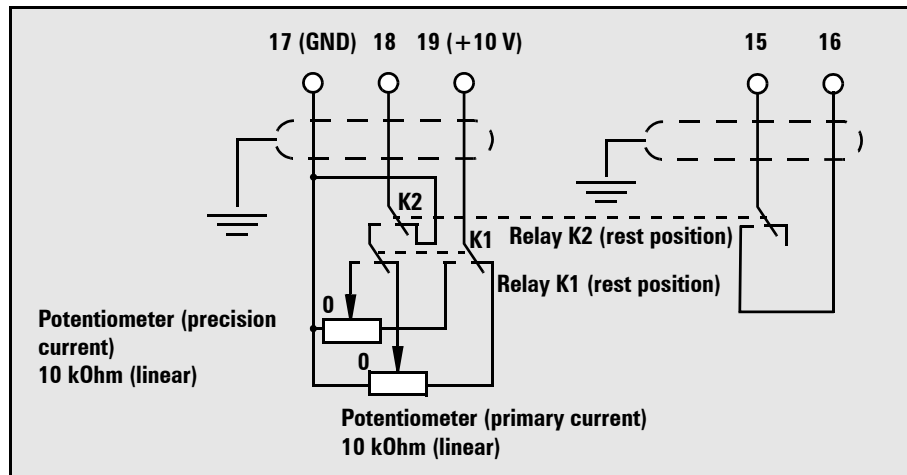

Figure 4.7 Course and fine fill rates



NOTE



NOTE

To prevent switching faults, use only gold-plated or hermetically sealed contacts.

Only potentiometers (limit value 10 kOhm) with a linear characteristic should be used as the vibration-width adjuster. Shield the signal lines to guarantee electromagnetic compatibility if the lines exceed five metres in length.

4.2.3 External control input

The controller can be operated with an external command value entry (external control input). The following external command values can be used for setting the working stroke (see Figure 4.8):

- 0...10 V DC, resistance 200 kOhm
- 4...20 mA DC, burden 250 Ohm
- 0...20 mA DC, burden 250 Ohm

Which of the three options you want to use has to be pre-selected by setting the (blue) spring clip on the control board (see Figure 4.8).

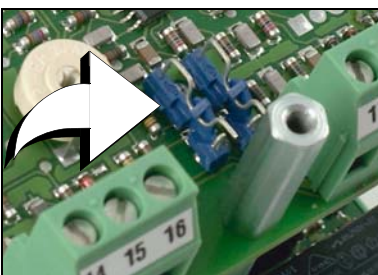

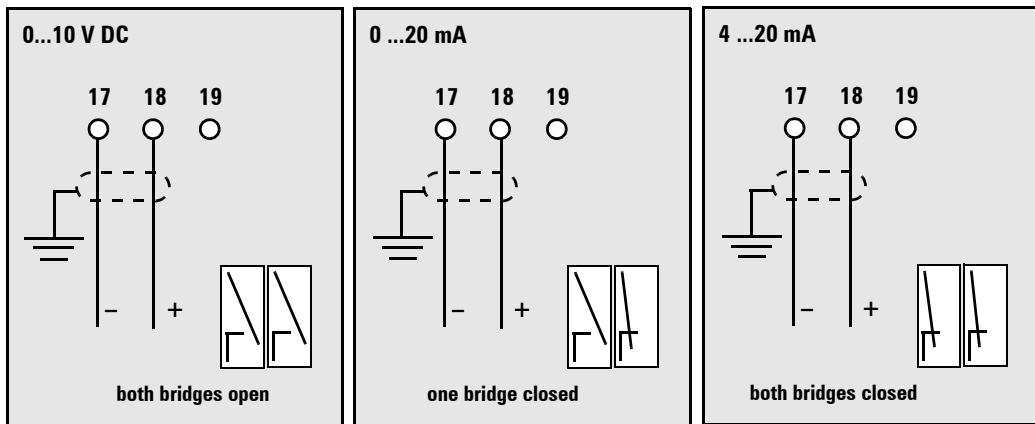

Figure 4.8 Options for the external command value specification

A switchable solution is possible for special applications (see Figure 4.9). In this case, a switch or a relay can be used to switch between the external control inputs or between command value presets using a vibration-width adjuster (potentiometer), as required.

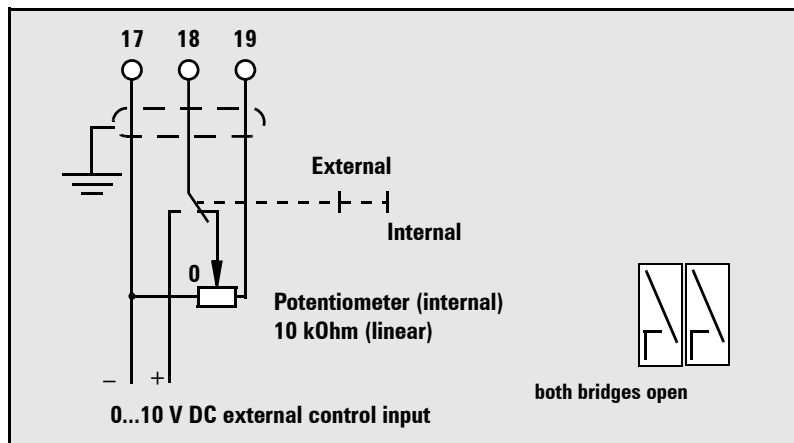

Figure 4.9 Switchable command value specification



NOTE

To prevent switching faults, use only gold-plated or hermetically sealed contacts.

Only potentiometers (limit value 10 kOhm) with a linear characteristic should be used as the vibration-width adjuster. Shield the signal lines to guarantee electromagnetic compatibility if the lines exceed five metres in length.

4.2.4 Switching on/off externally

If no external on/off switching (release) is required, terminals 15 and 16 must be connected by a wire bridge so that the magnetic vibrator can work.

Alternatively, the controller can be switched on and off externally using a switch (relay), an optical coupler or a direct-voltage signal. The relevant options for terminal assignment are given in siehe Figure 4.10.

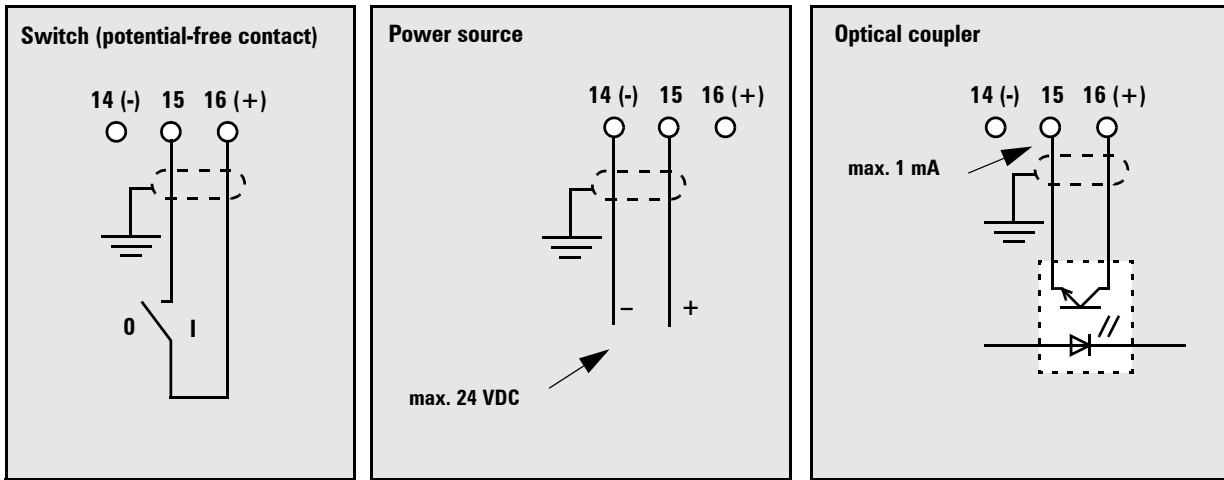

Figure 4.10 Options for switching on/off externally



ATTENTION!

Destruction of the controller: The maximum permissible load of 1 mA must be observed.



NOTE

To prevent switching faults, use only gold-plated or hermetically sealed contacts.

Shield the signal lines to guarantee electromagnetic compatibility if the lines exceed five metres in length.

4.2.5 Status relay

The controller has a status relay according to the following illustration:

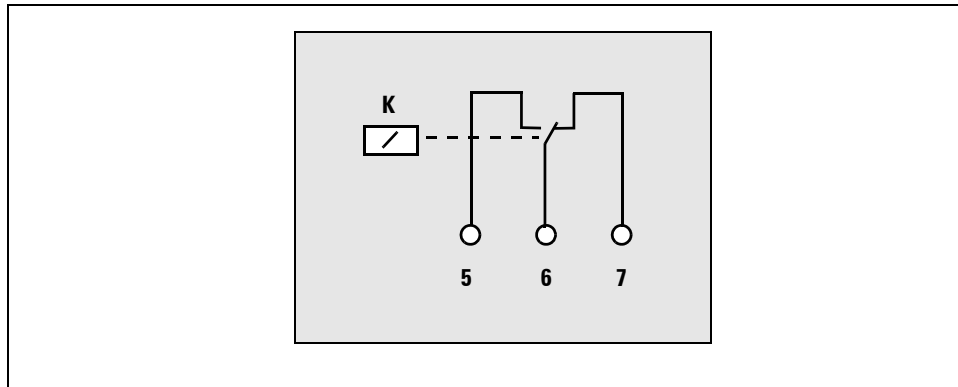

Figure 4.11 Status relay

The following switching states can be analysed:

Terminals 5 and 6	Terminals 6 and 7	Decrease
closed	open	Mains voltage (terminals 1 and 2) applied and a start signal is issued simultaneously (terminals 14, 15 and 16).
open	closed	Mains voltage (terminals 1 and 2) not applied, or <u>no</u> start signal issued when mains voltage is applied (terminals 14, 15 and 16).

Figure 4.12 Switching states of the status relay



The load rating for direct current is a maximum of 30 V DC, and for alternating current, a maximum of 250 V AC at a maximum current of 1.0 A. Destruction of the operational transmitting relay and possibly the controller! Observe the permissible values given above when dimensioning the load of the operational transmitting relay.

4.3 Electrical connection

4.3.1 Notes on electrical connections



.....
Avoid accidents - observe the regulations! VDE regulations and guidelines from your power company apply to earth, neutral line and protective circuit connections. The connection must be made only by trained personnel (certified electrician or electrically trained person in accordance with IEC 364 and EN 60204-1).
.....

- ☞ Switch off the current supply.
- ☞ Verify that no voltages are present.
- ☞ Ensure that the device cannot be reconnected accidentally.

Mains fuse

For mains protection at the customer's site, we recommend using a fuse (slow-blow) suitable for the nominal current of the connected magnetic drive.

Semi-conductor protection

On the controller conductor boards, there is a fuse link with fine-wire fuse close to the terminals (see figure, left). If this fuse fails, it must only be replaced with a fuse with the identical code (F6.3A/250V).

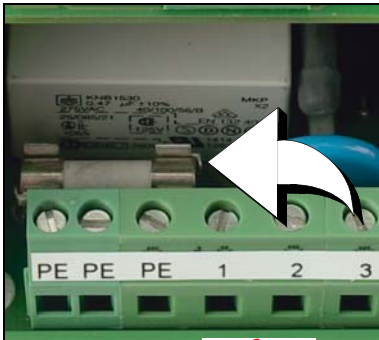

.....
The wrong fuse could result in damage to the magnetic drive. Observe the dimensioning of the mains protection at the customer's site and the fine-wire fuse fitted.
.....

4.3.2 Vibration-width adjuster, rotary-type knob and scale



Type SRA(E)...-1 controllers are supplied with a vibration-width adjuster (linear potentiometer with a limit value of 10 kOhm) (Technical data and dimensions siehe Figure 4.13).

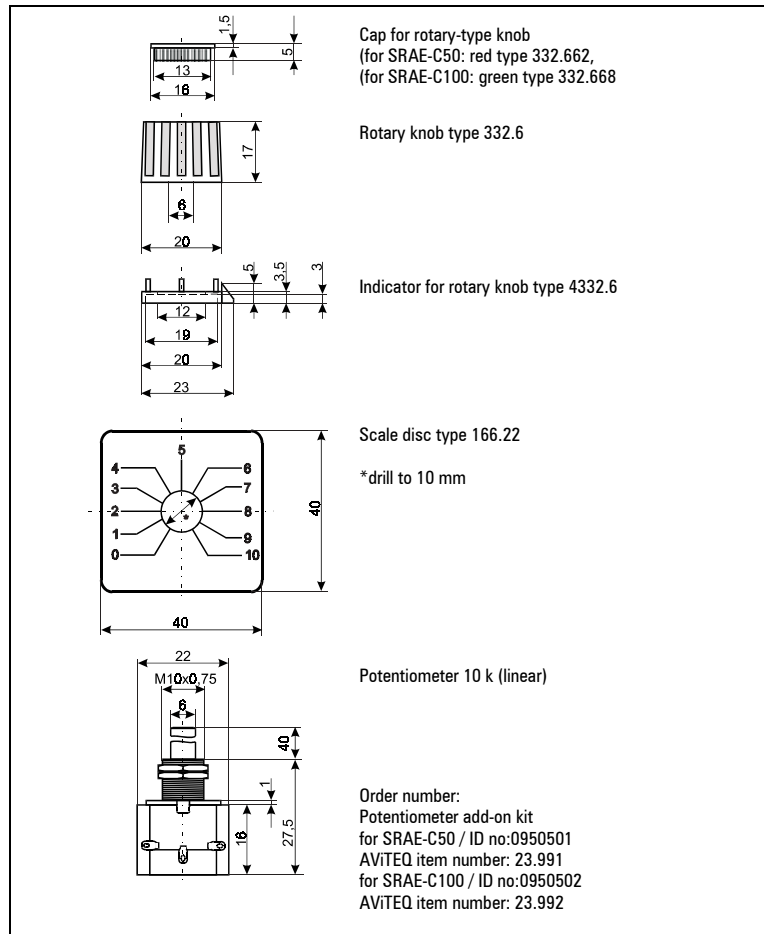

Figure 4.13 Potentiometer, rotary-type knob, scale for variants C50 and C100

4.4 Connection to the magnetic drive

This operating manual is included with each VIBTRONIC controller. A complete terminal plan is given at the start of Chapter 4.2.1.

- ☞ Make all the connections between the mains, controller, command value circuit and magnetic drive.

- ☞ Observe the specific features of the equipment in combination with the possible options, and also observe the terminal assignments given later in this manual.



.....
When connected to the mains, there are dangerously high voltages within the controller. Touching electrically live components can be fatal! Before switching on the mains power, ensure that it is not possible to touch any live parts. Close the cover on the control cabinet or close the switching cabinet door(s).
.....

4.4.1 Electromagnetic compatibility (EMC)

The series SRA(E)... -1 controllers have been developed and constructed conforming to EMC Directive 89/336/EEC. They fulfil the requirements of standards EN 50081-1 and EN 50082-2.



NOTE

.....
Observe the information regarding the shielding of signal lines described in the preceding chapters on terminal assignments.
.....

4.4.2 Line lengths



NOTE

.....
The line length is defined as the distance between the vibration conveyor device and the main distributor. Smaller line cross-sections or longer line lengths may cause faults.
.....

The maximum permissible *line length* is 200 m.

A *line cross-section* appropriate to the drive current should be used.

- ☞ The line cross-section corresponding to length can be found in the operating manual for the magnetic drive if required.
- ☞ Please note that only shielded cables should be used for signal lines exceeding the relevant line length specified. The shielding should be fitted on one side.



NOTE

.....
The maximum permissible voltage drop between the vibration conveyor device and the main distributor must not exceed a value of 5 %. If necessary, the line resistance should be calculated and checked.
.....

5 Commissioning

In principle the controllers can be operated both with original AViTEQ vibration conveyor devices and with equipment from third party manufacturers. This chapter describes the commissioning procedures required for both options.

A requirement for the commissioning process is the complete assembly of the vibration conveyor device with small-parts conveyor drive or bowl feeder drive or magnetic vibrator.

In addition, all the assembly work must be completed as described and explained in the previous chapter (chapter 4).

5.1 AViTEQ magnetic drives

The commissioning process for the original AViTEQ magnetic drive is best carried out in accordance with the commissioning steps in the relevant chapter of the magnetic drive operating manual (small-parts conveyor drive or bowl feeder drive).

Should any faults occur, please refer to chapter 7 later on in this operating manual. More information can be found in the *Troubleshooting* chapter in the operating manual for the AViTEQ magnetic drive or for the AViTEQ vibration conveyor device.

5.2 Third party drives

5.2.1 Setting the nominal vibrator voltage

The correct term for the controller output voltage is “drive voltage”. However, as the term “nominal vibrator voltage” has become more common, this expression will be used in this section.

The nominal vibrator voltages (drive voltages) $U_{V,min}$ and $U_{V,max}$ which can be measured on terminals 3 and 4 on the controller, are factory set to a fixed value for using original AViTEQ equipment.

If a third party magnetic drive is to be used, the setting for the nominal vibrator voltage should be checked and adjusted if necessary.

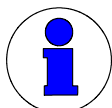

NOTE

The setting work for the nominal vibrator voltage can be carried out by AViTEQ Vibrationstechnik; in this event, please state the actual nominal vibrator voltage of your third party device when ordering the controller.

If you want to set the nominal vibrator voltage yourself, please follow the steps given below for the commissioning procedure.

5.2.2 Commissioning, step-by-step

For the commissioning process, please also see the commissioning instructions from the third party manufacturer of your magnetic drive.

We recommend the procedure given below, which should be the same as the instructions for the third party equipment.

- 1 Prerequisites: Has the work for assembling the working unit and the magnetic drive and for cabling for the controller been completed?



NOTE

For magnetic drives and/or working units not supplied by AViTEQ Vibrationstechnik, no definite predictions can be made for the behaviour of the vibration device in this operating manual. If necessary, please contact the third party manufacturer. AViTEQ Vibrationstechnik cannot accept any responsibility for the correct functioning of the AViTEQ controller used in combination with vibration conveyor devices from third party manufacturers.

- 2 The commissioning procedure must be carried out using the lowest working stroke: Turn the vibration-width adjuster (potentiometer) on the controller to a scale value of around 10 %. Or: For an *external control input* set the lowest control input value. Now switch on the controller.



NOTE

The commissioning process is carried out at a low working stroke in order to be able to detect any damage caused by assembly errors for the vibration behaviour of the entire vibration conveyor device which is undetected at this point. Example: The working unit collides with neighbouring conveyor components or works in collision mode.

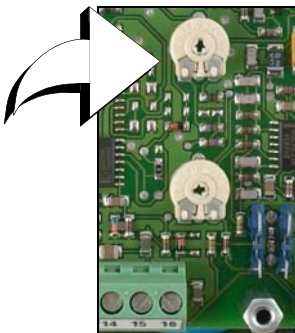

- 3 Please listen for any *hammering* noises that indicate the *collision mode*. This *collision mode* may result in the destruction of the drive. If hammering noises occur, reduce the working stroke by lowering the command value set (turn potentiometer to the left or reduce external third party command value), until the hammering noise stops. Turn the trimming potentiometer "U_{max}" at the top of the control board approx. 10° anti-clockwise to reduce the vibrator voltage.



DANGER!

Fatal voltage levels! Take appropriate steps (cover live components) to prevent accidents.

- 4 Increase the working stroke by gradually turning the vibration-width adjuster (potentiometer) or by increasing the external command input, until the maximum value (fully to the right or scale value at "10" on the vibration-width adjuster or maximum third party command value) has been reached.



NOTE

Even if the maximum position on the potentiometer (end scale value "10") is not used later on, this position should still be tested during the commissioning process to ensure that the vibration conveyor device also functions correctly at the maximum potentiometer-setting or command value.

- ☞ Connect a voltmeter to a suitable measurement range (recommendation: 750 V AC) to terminals 3 and 4 on the controller. With a digital voltmeter, select the maximum measurement range (750 V or 1000 V).



Fatal voltage levels! Take appropriate steps (cover live components) to prevent accidents.



NOTE

Only meters which display the root mean square value should be used for measuring the voltage (moving iron instrument or "true RMS"). Other measuring devices would not produce relevant measurements when measuring the non-sinusoidal voltage curve. For digital measuring devices, select ≥ 750 V to avoid incorrect measurements due to the crest factor.

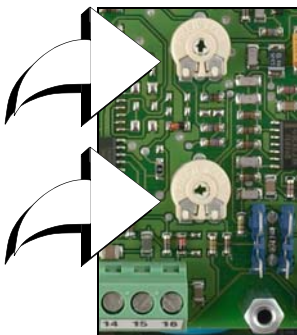

- 5 Compare the measured vibrator voltage to the manufacturer specifications for the magnetic drive and if necessary, set the specified value by adjusting the trimming potentiometer " U_{max} " at the top of the control board (see illustration opposite).

Set the maximum permissible vibrator voltage only with a maximum command value. To do this, turn the vibration-width adjuster fully to the right (scale value "10") or set the maximum value (e.g. 20 mA) for an external control input.

- ☞ To do this, turn the vibration-width adjuster (potentiometer) fully to the left or the scale value "0", or set the maximum value for an external control input, e.g. 4 mA.
- ☞ Then measure the vibrator voltage again. If this is too high, the lower trimming potentiometer " U_{min} " at the bottom of the control board can be used to reduce the minimum vibrator voltage.

Repeat this step until the required voltage for $U_{v,min}$ and $U_{v,max}$ has been reached.



NOTE

There is interaction between the trimming potentiometer " U_{min} " and " U_{max} ".

- 6 If the value specified for the vibrator voltage cannot be set because this causes a hammering noise, switch off the device and refer to chapter 7 (Troubleshooting).



ATTENTION!

.....
Collision mode results in the destruction of the magnetic drive! This must therefore be avoided as far as possible when setting the vibrator voltage.
.....

- 7 Measure the vibrator current using a moving iron instrument or using a device which measures the true root mean square value in a frequency range of 0 to 500 Hz; compare the values to the manufacturer's data for the vibration conveyor device being used.



NOTE

.....
Only meters which display the root mean square values should be used for measuring the current (moving iron or "true RMS" instrument). Other measuring equipment with a measurement range not equal to 0-500 Hz (without DC) would not produce relevant measurements when measuring the non-sinusoidal voltage curve.
.....



DANGER!

.....
Live components. If the equipment is not unplugged, there is a risk of fatal electric shock. When subsequently carrying out measurements, observe the safety measures specified.
.....

- 8 In addition, measure the maximum working stroke and compare the value to the manufacturer data for the vibration device being used.
- 9 The permissible measurements for the nominal vibrator current and voltage given on the type label must not be exceeded. Otherwise there is a risk of destruction due to collision mode.
- 10 If the working stroke specified by the manufacturer is not reached, the natural frequency of the vibration device should be checked as necessary.

6 Maintenance

In general, all AVITEQ controller versions are maintenance free. In dusty environments, however, there may be dust penetration and deposits may form. This may result in the deterioration of the cooling system for the control electronics or short circuits as a result of soiled strip conductors.

Check the following at regular intervals:

- ☞ Is there any dust penetration? Determine the cause so that measures can be taken to avoid the problem in future. Clean the controller by vacuuming off the dust layer, e.g. using an industrial vacuum cleaner.
- ☞ A suitable cleaning interval should be set depending on the amount of dust in the environment around the controller.



NOTE

.....
For cleaning using compressed air, please observe any company regulations regarding dust disturbance.
.....



DANGER!

.....
Disturbed dust can mix with air and form explosive dust-air mixtures. Take all appropriate measures to eliminate the risk of explosion.
.....



DANGER!

.....
When connected to the mains, there are dangerously high voltages within the controller. Touching live electrical components can be fatal! Before cleaning the controller, switch off the power supply and secure against accidental activation, including by other staff members. Protect yourself against accidental contact with adjacent live electrical components or modules.
.....

7 Fault Causes and Remedies



Disassembling the controller is potentially fatal and may result in damage to the device. There are no components within the device which can be maintained or repaired by the user. Do not attempt to carry out any repairs yourself. Never disassemble the controller, even if the power supply has been disconnected. In the event of device malfunction, ship the entire device to AVITEQ Vibrationstechnik, Hattersheim, Germany. We will ensure that your device is repaired as quickly as possible.

	Fault	Cause(s)	Remedy
1)	Vibration conveyor device is not functioning.	No mains voltage.	Correct fault source, check fuse(s)
		Mains fuse blown.	Replace fuse, check power intake if necessary
		Supply line interrupted.	Determine cause and replace supply line
		Full mains voltage on terminals 3 and 4 (identical to voltage at terminals 1 and 2).	Check the connection between the controller and the drive.
		Triac short-circuit, drive is making buzzing noise.	Replace Triac.
		Controller component(s) (Triac, supply transformer, board, etc.) faulty, no voltage at output terminals 3 and 4	Repair required. Send controller to AVITEQ Vibrationstechnik.
		Vibration-width adjuster (potentiometer) or its supply line faulty.	Replace vibration-width adjuster or its supply lines, consult AVITEQ Vibrationstechnik if necessary
		Terminals 15 and 16 are not connected with a bridge.	Check switch (relay), external voltage or optical coupler, if fitted, or use bridge; or connect the terminals using a switch (relay) or an optical coupler.
	Signal line(s) interrupted	Replace signal line(s)	
2)	Vibration conveyor device output too low	Wrong controller chosen.	Assign correct controller, check AVITEQ Vibrationstechnik delivery specifications.
		Voltage at controller output (terminals 3 and 4) too low	Check mains voltage and controller setting. Check drive and controller voltage specifications; increase drive voltage on "Umax" trimming potentiometer if necessary, or consult AVITEQ Vibrationstechnik.
		Voltage on drive input too low	Supply line too long (... high resistivity), change supply line (length, diameter), consult AVITEQ Vibrationstechnik as necessary
		Deviation from nominal frequency at in-house current supply	Re-tuning required; check with AVITEQ Vibrationstechnik
		Potentiometer (terminals 17, 18 and 19) not connected, no external control input available.	Connect potentiometer or external control input
		Controller is supplying incorrect drive frequency; as a result the drive current I _v is too high and the fuse may blow.	Repair or re-adjustment required. Send controller to AVITEQ Vibrationstechnik.

Table 7
Fault Causes and Remedies

	Fault	Cause(s)	Remedy
3)	Drive is running in collision mode (hammering noise).	Drive voltage too high	Check mains voltage and controller setting. Check drive and controller voltage specifications; reduce drive voltage on "Umax" trimming potentiometer if necessary, or consult AViTEQ Vibrationstechnik.
		Nominal frequency deviation in in-house main supply.	Re-tuning required; check with AViTEQ Vibrationstechnik
		Excessive useable weight and/or natural frequency too low	For small-parts conveyor drives and bowl feeder drives, compare useable weight with the unit weight on the type label (tray, pan, bar or similar). A new agreement with AViTEQ Vibrationstechnik may be required as necessary. Please ask us!
		Wrong controller chosen. Incorrect vibration frequency set.	Assign correct controller, check delivery specifications from AViTEQ Vibrationstechnik.
4)	Drive is running at max. working stroke, regardless of the potentiometer setting.	Signal line at terminal 17 is interrupted.	Check and replace signal line.
5)	Potentiometer is not supplying a virtually linear working stroke path according to the angle of rotation.	Potentiometer connected to wrong terminals (connected as series resistance).	Connect potentiometer correctly.

**Table 7 (Forts.)
Fault Causes and Remedies**



NOTE

The problems listed above mostly relate to the controller. Further faults, caused by the working unit or the small-parts conveyor drive or bowl feeder drive, can be found in the appropriate operating manual.

8 INDEX

A

Ambient temperatures 1-4

B

Beryllium 2-2

C

Cabinet unit 1-1, 3-3, 4-3

Climatic conditions 1-4

Collision mode 5-4

Controller 1-1

Cooling 6-1

Command value specification 3-, 3-3

Controller 1-1

Copyright 0-4

Course and fine fill rates 4-6

D

Disposal 2-2

Dust 6-1

E

Electrical connection 4-10

EMC Directive(89/336/EWG) 3-1, 4-12

Environments with explosion hazards 0-3, 1-4

External release 3-2

Extent of delivery 2-1

F

Fault causes 7-1

Fuse 0-3, 4-10

G

General Terms and Conditions 0-4

H

Height 1-4

I

Installation 4-1

Installation and operating personnel 1-4

Intended use 0-2

L

Level of contamination 1-4

Line-cross section 4-12

Line lengths 4-12

M

Magnetic drive 1-1

Magnetic drives by other manufacturers 1-3

Magnetic vibrator 1-1

Mains frequency 3-1, 3-3

Mains voltage fluctuations 3-1

Maintenance 6-1

Minimum distances 4-1

Moving iron instrument 5-3, 5-4

N

Natural frequency 5-4

Nominal voltage vibrator 5-1

O

Operating messages 3-2

Operative range 1-3

Oscillation rates 3-1, 3-3

Output current 3-3

P

Packaging material 2-2

Panel mounting 1-1, 3-3, 4-2

Potentiometer 4-5, 4-11

Power loss 3-3

Product liability 1-2

Protective conductor connections 0-3

R

Repairs 1-5

RMS instrument 5-3, 5-4

S

Safety 0-2

Scope of operation 3-1

Semi-conductor protection 4-10

Small-parts conveyor drive 1-1

Soft start 3-3

Specialist staff 1-1

Status relay 3-3, 4-9

Storage 2-1

Storage temperature 1-4

Switching on/off externally 4-8

T

Technical data 3-3

Terminal plan 4-4

Third party drives 5-1

Transport 2-1

True RMS 5-3, 5-4

Type designations 3-4

V

Vibration conveyor device 1-1

Voltage drop 4-12

W

Warranty conditions 1-2

Warranty exclusions 1-2

EC Declaration of Conformity

Manufacturer:

AVITEQ Vibrationstechnik GmbH
Im Gotthelf 16
D-65795 Hattersheim-Eddersheim, Germany

Product description:

Controllers for small-parts conveyor drives, bowl feeder drives and magnetic vibrators

Device types:

SRA...-1, SRAE...-1

The products of the specified type series conform to the specifications in the following European Directive:

89/336/EEC Directive of the Council for Conformity of Legal Regulations of Member States on Electromagnetic Compatibility, updated by 91/263/EEC, 92/31/EEC and 93/68/EEC

The conformity of the products with the European Directives is evidenced by complete compliance with the following harmonised standards:

DIN EN 50081-1
DIN EN 50082-2

Full technical documentation is available. The operating manual for the devices is also available. The CE symbol has been attached.

The safety notes in the operating manual supplied must be observed.

This declaration assures conformity with the standards and directives cited, but does not represent any guarantee of specific features.

Hattersheim-Eddersheim, Germany, 1st September 2001

Legally binding signature:



Nickmann, AVITEQ/APB

AVITEQ Vibrationstechnik GmbH

Im Gotthelf 16

D-65795 Hattersheim-Eddersheim, Germany

Phone: +49 (0) 61 45 / 5 03 - 0

Fax: +49 (0) 61 45 / 5 03 - 200

Fax Service Hotline: +49 (0) 61 45 / 5 03 - 112

 VIB 12.83 / 0102 EN